

EJERSTED

3600725

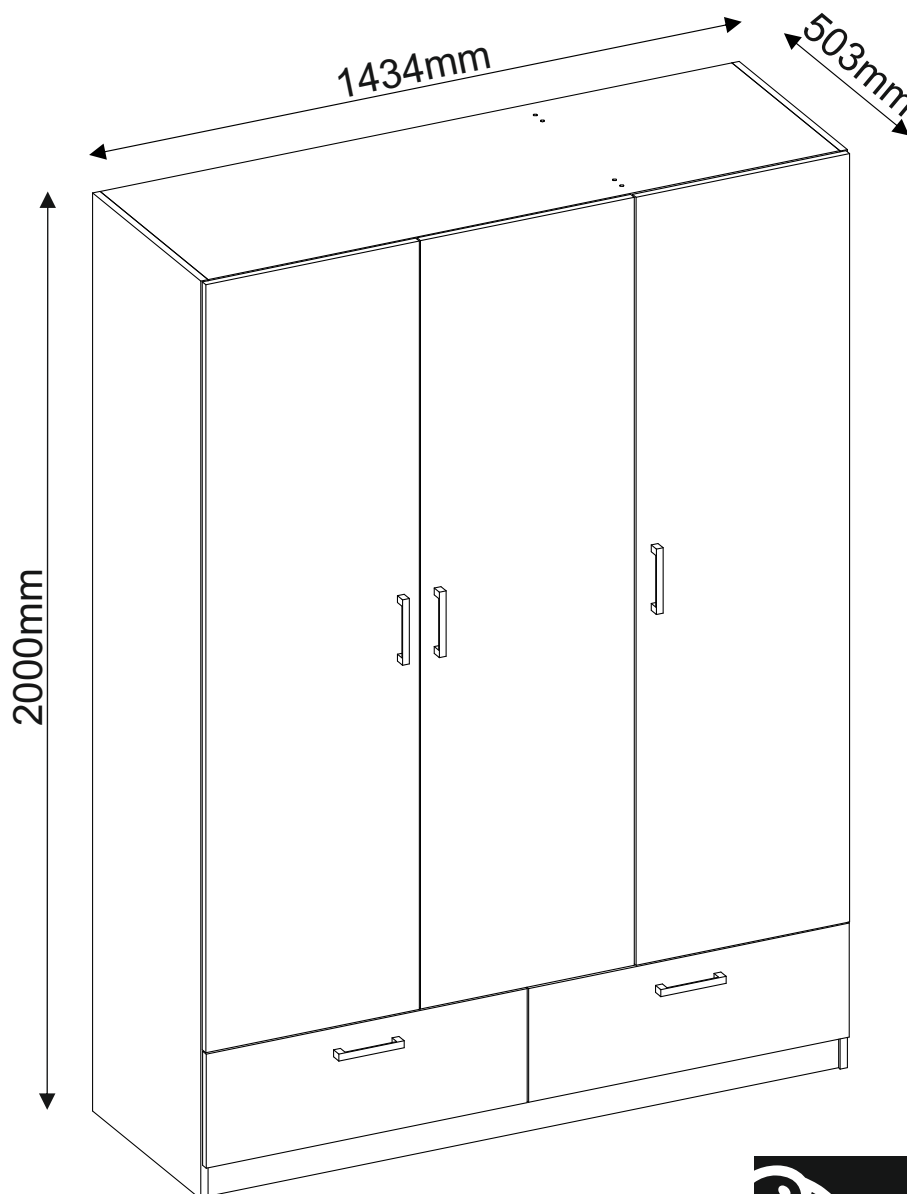

JYSK.com

GB: IMPORTANT INFORMATION!

Please read the entire manual carefully before starting to assemble and/or using this product. Follow the manual thoroughly and keep it for further reference.

DK: VIGTIG INFORMATION!

Læs hele manualen grundigt igennem før samling og/eller brug af dette produkt. Følg manualen nøje, og opbevar den til senere brug.

SE: VIKTIG INFORMATION!

Läs bruksanvisningen i sin helhet innan du börjar att montera och/eller använda produkten. Följ bruksanvisningen noggrant och spara den för framtida referens.

NO: VIKTIG INFORMASJON!

Les hele bruksanvisningen nøye før du begynner å montere og/eller bruke dette produktet. Følg bruksanvisningen nøye, og ta vare på den for fremtidig bruk.

FI: TÄRKEITÄ TIETOJA

Lue käyttöohjeet kokonaan ennen tämän tuotteen kokoamista ja/tai käyttöä. Noudata käyttöohjeita tarkasti ja säilytä ne myöhempää tarvetta varten.

PL: WAŻNE INFORMACJE.

Przed użyciem produktu należy dokładnie zapoznać się ze wskazówkami bezpieczeństwa. Należy zapoznać się z instrukcją obsługi i zachować ją do użytku w przyszłości.

CZ: DŮLEŽITÉ INFORMACE!

Před sestavením nebo použitím výrobku si pečlivě přečtěte celý návod. Dodržujte důsledně uvedené pokyny a návod uschovejte, aby byl k dispozici v případě potřeby.

HU: FONTOS INFORMÁCIÓ

A termék összeszerelésének vagy használatának megkezdése előtt figyelmesen olvassa el a teljes útmutatót. Őrizze meg az útmutatót, és gondosan tartsa be a benne foglaltakat.

SK: DŮLEŽITÉ INFORMÁCIE!

Predtým ako začnete s montážou a/alebo používaním tohto produktu si pozorne prečítajte celý návod. Návod dôsledne dodržiavajte a ponechajte si ho pre použitie v budúcnosti.

NL: BELANGRIJKE INFORMATIE!

Lees de volledige handleiding zorgvuldig door voordat u dit product monteert en/of gebruikt. Volg de handleiding zorgvuldig en bewaar deze voor toekomstig gebruik.

SI: POMEMBNE INFORMACIJE!

Pred montažo/uporabo izdelka pozorno preberite ta navodila za uporabo. Upoštevajte navodila in jih shranite, saj jih boste morda še potrebovali.

RU: ВАЖНАЯ ИНФОРМАЦИЯ!

Внимательно и полностью прочитайте это руководство, прежде чем приступать к сборке или использованию этого изделия. Следуйте всем инструкциям этого руководства и сохраните его на будущее для справки.

HR: VAŽNE OBAVIJESTI!

Molimo Vas pažljivo pročitajte upute za uporabu prije sastavljanja i/ili korištenja ovog proizvoda. Strogo se pridržavajte uputa i sačuvajte ih za buduće potrebe.

BA: VAŽNE INFORMACIJE!

Prije sklapanja i/ili korištenja ovog proizvoda, pažljivo pročitajte cijeli priručnik. Pažljivo se pridržavajte uputstava u priručniku i sačuvajte ga za buduću upotrebu.

CN: 重要信息!

组装和/或使用本产品之前请通读该手册。请严格遵循手册说明，保留手册供日后参考。

RS: VAŽNE INFORMACIJE!

Pažljivo pročitajte kompletan priručnik pre nego što počnete da sklapate i/ili koristite ovaj proizvod. Detaljno sledite priručnik i sačuvajte ga za kasniju upotrebu

UA: ВАЖЛИВА ІНФОРМАЦІЯ.

Уважно прочитайте весь посібник, перш ніж збирати та/чи використовувати цей продукт. Виконайте всі інструкції цього посібника та збережіть його для подальшого використання.

RO: INFORMAȚII IMPORTANTE

Citiți cu atenție întregul manual înainte de a începe să montați și/sau să utilizați acest produs. Urmați îndeaproape instrucțiunile din manual și păstrați-l pentru consultare ulterioară.

BG: ВАЖНА ИНФОРМАЦИЯ!

Моля, прочетете цялото ръководство внимателно, преди да започнете да сглобявате и/или използвате този продукт. Следвайте стриктно ръководството и го пазете за бъдещи справки.

GR: ΣΗΜΑΝΤΙΚΕΣ ΠΛΗΡΟΦΟΡΙΕΣ!

Διαβάστε προσεκτικά ολόκληρο το εγχειρίδιο πριν από τη συναρμολόγηση ή/και τη χρήση του προϊόντος. Ακολουθήστε προσεκτικά τις οδηγίες του εγχειριδίου και κρατήστε τις για μελλοντική αναφορά.

TR: ÖNEMLİ BİLGİLER!

Bu ürünün montajını yapmaya başlamadan ve/veya ürünü kullanmadan önce lütfen kılavuzun tamamını dikkatlice okuyun. Kılavuzu adım adım izleyin ve daha sonra başvurmak üzere saklayın.

FR: INFORMATIONS IMPORTANTES

Veuillez lire attentivement l'ensemble du manuel avant de commencer à monter et/ou utiliser ce produit. Suivez rigoureusement le manuel et conservez-le pour toute consultation ultérieure.

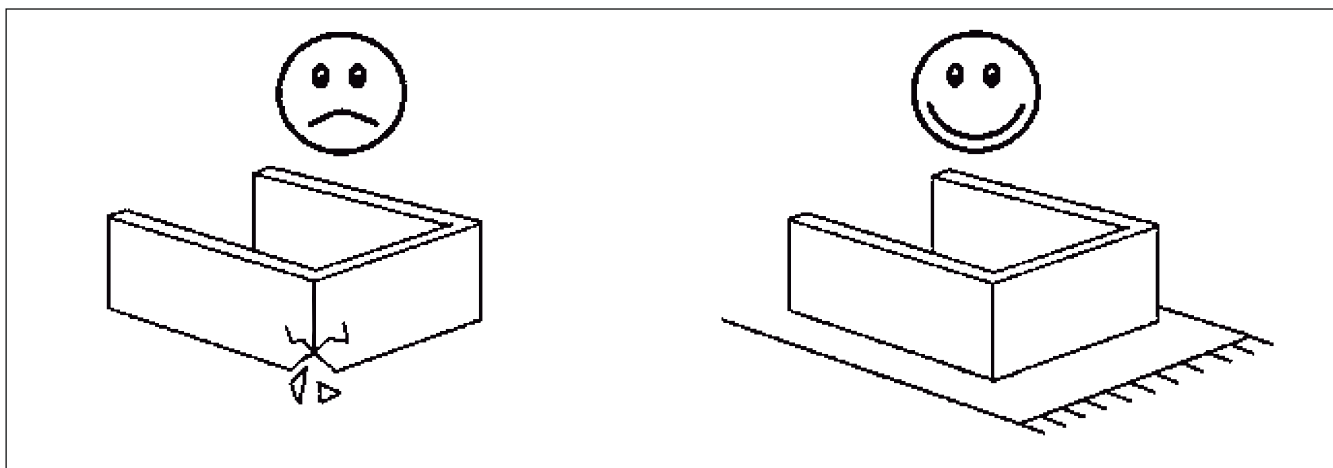

GB: WARNING TO AVOID SCRATCHES!

In order to avoid scratching this furniture should be assembled on a soft layer - could be a rug.

DK: ADVARSEL FOR AT FORHINDRE RIDSER!

For at forhindre ridser skal dette møbel samles på et blødt underlag, f.eks. et tæppe.

SE: VARNING OM HUR DU UNDVIKER REPOR!

För att undvika repor ska denna möbel monteras på ett mjukt underlag, exempelvis en matta.

NO: ADVARSEL FOR Å UNNGÅ RIPER!

For å unngå riper må møbelet monteres på et mykt underlag, for eksempel et teppe.

FI: VARO NAARMUJA!

Varo naarmuja ja kokoa tämä kaluste pehmeällä alustalla, esimerkiksi maton päällä.

PL: OSTRZEŻENIE WS. USZKODZEŃ

Aby uniknąć rys, ten mebel powinien być montowany, składany na miękkim podłożu, np. dywanie.

CZ: VAROVÁNÍ TÝKAJÍCÍ SE POŠKRÁBÁNÍ!

Aby nedošlo k poškrábání, sestavujte nábytek na měkkém podkladu – např. na koberci.

HU: KARCOLÁSOK MEGELŐZÉSE – FIGYELEM!

A karcolások megelőzése érdekében a bútort puha felületen, például szőnyegen kell összeszerelni.

SK: VÝSTRAHA TÝKAJÚCA SA PREDCHÁDZANIA ŠKRABANCOM!

Aby sa predišlo škrabancom, tento nábytok by sa mal montovať na mäkkom podklade, napríklad na koberci.

NL: WAARSCHUWING OM KRASSEN TE VERMIJDEN!

Om te voorkomen dat dit meubel krassen vertoont, moet het gemonteerd worden op een zachte ondergrond - zoals een tapijt

SI: KAKO PREPREČITI PRASKE!

Da bi se izognili praskam na pohištvu, pohištvu sestavite na mehki podlagi, npr. na preprogi

RU: ПРЕДУПРЕЖДЕНИЕ ОТНОСИТЕЛЬНО ЦАРАПИН!

Во избежание нанесения царапин, сборку этой мебели необходимо выполнять на мягкой поверхности, например на ковре.

HR: UPOZORENJE O IZBJEGAVANJU OGREBOTINA!

Kako bi se izbjegle ogrebotine, ovaj proizvod potrebno je sastavljati na mekanoj površini - primjerice, na tepihu.

BA: UPOZORENJE ZA SPRJEČAVANJE NASTANKA OGREBOTINA!

Da bi se izbjegle ogrebotine na ovom namještaju, poželjno ga je sastaviti na mekoj podlozi - na primjer, tepihu.

CN: 防刮警告!

为了避免刮伤家具，应在地毯等软面上进行组装。

RS: UPOZORENJE ZA IZBEGAVANJE OGREBOTINA!

Da biste izbegli ogrebotine, ovaj nameštaj treba da sastavljate na mekoj podlozi - može prostirka.

UA: ПОПЕРЕДЖЕННЯ ЩОДО ПОДРЯПИН.

Щоб уникнути подряпин, ці меблі слід збирати на м'якій поверхні, наприклад, на килимі.

RO: ATENȚIONARE PENTRU EVITAREA ZGĂRIERII!

Pentru evitarea zgărierii, această piesă de mobilier trebuie să fie montată pe o suprafață moale, de exemplu, pe un covor.

BG: ПРЕДУПРЕЖДЕНИЕ ЗА ИЗБЯГВАНЕ НА ДРАСКОТИНИ!

За да избегнете надраскване, тази мебел трябва да бъде сглобена на мека повърхност – например килим.

GR: ΠΡΟΕΙΔΟΠΟΙΗΣΗ ΓΙΑ ΤΗΝ ΑΠΟΦΥΓΗ ΓΡΑΤΣΟΥΝΙΩΝ!

Για την αποφυγή γρατσουνιών, το έπιπλο θα πρέπει να συναρμολογηθεί σε μαλακή επιφάνεια, όπως για παράδειγμα πάνω σε ένα χαλί.

TR: ÇİZİLMELERİ ÖNLEMENE YÖNELİK UYARI!

Bu mobilyanın çizilmesini engellemek için montajını halı gibi yumuşak bir yüzeyin üzerinde yapın.

FR: AVERTISSEMENT POUR ÉVITER LES RAYURES

Afin d'éviter les rayures, ce meuble doit être monté sur une surface souple (un tapis, par exemple).

GB: IMPORTANT!

It is important that any product which is assembled using any kind of screw is re-tightened 2 weeks after assembly, and once every 3 months - in order to assure stability through-out the lifespan of the product.

DK: VIGTIGT!

Det er vigtigt, at alle produkter, der samles med alle former for skruer, efterspændes to uger efter samling samt hver tredje måned for at sikre, at produktet er stabilt i hele dets levetid.

SE: VIKTIGT!

För alla produkter som monteras med skruv är det viktigt att dessa efterdras två veckor efter monteringen och därefter en gång var tredje månad. Detta för att säkerställa att produkten håller sig stabil under hela sin livslängd.

NO: VIKTIG!

Det er viktig at alle produkter som monteres med skruer blir etterstrammet 2 uker etter montering, og hver 3. måned for å sikre stabiliteten gjennom hele produktets levetid.

FI: TÄRKEÄÄ!

On tärkeää, että kaikki ruuvien avulla koottavat tuotteet kiristetään uudelleen 2 viikkoa kokoamisen jälkeen ja aina 3 kuukauden välein, jotta tuote pysyy vakaana koko käyttöikänsä ajan.

PL: WAŻNE!

Ważne jest, żeby każdy ze skręcanych produktów został ponownie dokręcony w ciągu 2 tygodni od montażu, a następnie sprawdzac co 3 miesiące czy śruby są dokręcone – w celu zapewnienia stabilności przez czas użytkowania produktu.

CZ: DŮLEŽITÉ!

U každého výrobku, který se sestavuje pomocí jakýchkoli šroubků, je důležité dotáhnout šroubky 2 týdny po sestavení a potom každé 3 měsíce, aby byla zajištěna stabilita po celou dobu životnosti výrobku.

HU: FONTOS!

Minden terméknel fontos, hogy bármilyen fajta csavarral is történi az összeszerelése, utána 2 héttel, majd 3 havi rendszerességgel szükséges a csavarok utánhúzása. Ezzel a termék teljes élettartamán keresztül biztosítható a stabilitása.

SK: DŮLEŽITÉ!

Je dôležité, aby sa na akomkoľvek produkte, montovanom pomocou akýchkoľvek skrutiek, skrutky dotiahli po dvoch týždňoch od montáže, a jedenkrát v priebehu každých 3 mesiacov – tak sa zaručí stabilita počas celej životnosti produktu.

NL: BELANGRIJK!

Het is belangrijk om elk product dat met om het even welk soort schroef wordt gemonteerd, twee weken na montage en om de drie maanden, opnieuw wordt vastgeschroefd, om de stabiliteit van het product tijdens de hele levensduur te verzekeren.

SI: POMEMBNO!

Vsak izdelek, ki ga sestavite z uporabo kakršnihkoli vijakov morate 2 tedna po sestavitvi ponovno pregledati in vijake po potrebi priviti. To ponovite vsake 3 mesece, da bi zagotovili stabilnost izdelka skozi njegovo celotno življenjsko dobo.

RU: ВАЖНО!

В любом изделии, собранном с использованием винтов любого типа, необходимо через 2 недели после сборки и в дальнейшем каждые 3 месяца подтягивать винты, чтобы обеспечить прочность изделия в течение срока эксплуатации.

HR: VAŽNO!

Važno je da se svi tipovi vijaka na bilo kojoj vrsti proizvoda koji se s pomoću njih sastavlja ponovno pritegnu 2 tjedna nakon sastavljanja te jednom svaka 3 mjeseca - kako bi se zajamčila stabilnost tijekom životnog vijeka proizvoda.

BA: VAŽNO!

Za sve proizvode sa vijčanim vezama, potrebno je izvršiti pritezanje 2 sedmice nakon sklapanja i svaka 3 mjeseca nakon toga, kako bi se osigurala stabilnost tokom cijelog životnog vijeka proizvoda.

CN: 重要提示!

使用任何类型的螺钉组装的产品，必须在组装 2 周后重新拧紧，并且每 3 个月重新拧紧一次，以确保产品在整个使用期内结实稳固。

RS: VAŽNO!

Važno je da svaki proizvod koji je sklopljen korišćenjem bilo kakvih šrafova bude ponovo pričvršćen 2 nedelje nakon sklapanja i jednom svaka 3 meseca - kako bi se obezbedila stabilnost tokom celog veka trajanja proizvoda.

UA: УВАГА.

Майте на увазі, якщо у процесі монтажу продукту використовуються гвинти будь-якого типу, їх треба повторно затягнути через 2 тижні після монтажу, а потім кожні 3 місяці. Це необхідно для того, щоб забезпечити надійне використання продукту протягом терміну його служби.

RO: IMPORTANT!

Este important ca şuruburile de orice tip, cu ajutorul cărora au fost montate produsele, să fie strânse din nou la 2 săptămâni după montare şi, apoi, o dată la 3 luni, pentru a se asigura stabilitatea de-a lungul duratei de viaţă a produsului.

BG: ВАЖНО!

Важно е всеки продукт, който е сглобен с помощта на винтове, да бъде затегнат 2 седмици след сглобяването, и веднъж на всеки 3 месеца, за да се гарантира стабилност през цялото време на използване на продукта.

GR: ΣΗΜΑΝΤΙΚΟ!

Για κάθε προϊόν που συναρμολογείται με βίδες είναι σημαντικό αυτές να ξανασφιγγονται 2 εβδομάδες μετά τη συναρμολόγηση και μία φορά κάθε 3 μήνες, για τη διασφάλιση της σταθερότητας σε όλη τη διάρκεια ζωής του προϊόντος.











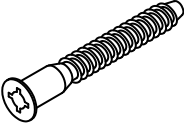
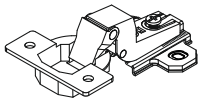
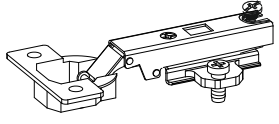
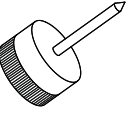

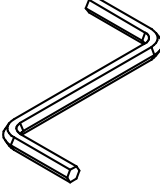
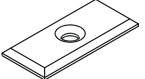
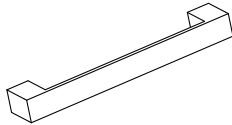
TR: ÖNEMLİ!

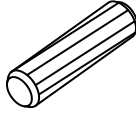
Vida kullanılarak yapılan her türlü ürün montajı için montajdan 2 hafta sonra vidaların yeniden sıkıştırılması ve kullanım süresi boyunca ürün istikrarının sağlanması için de her 3 ayda bir vidaların sıkıştırılması önem arz eder.

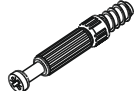
FR: IMPORTANT

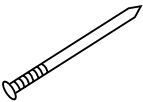
Il est important que tout produit monté à l'aide de vis soit resserré 2 semaines après son montage, puis tous les 3 mois, afin de garantir sa stabilité durant tout son cycle de vie.

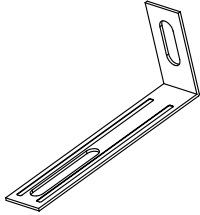
<p>GB: GENERAL INSTRUCTION FOR FURNITURE MADE OF WOOD OR WOOD COMPOSITES SUCH AS MELAMINE, LAMINATE OR VENEER SURFACES! Wipe clean with a damp cloth. Use only water or a gentle detergent. Wipe dry with a clean cloth.</p>
<p>DK: GENEREL VEJLEDNING TIL MRBLER FREMSTILLET AF TRÆ ELLER TRÆKOMPOSITMATERIALER SOM MELAMIN, LAMINAT ELLER FINER! Rengøres med en fugtig klud. Anvend kun vand eller et mildt vaskemiddel. Tørres af med en ren klud.</p>
<p>SE: ALLMÄNNA INSTRUKTIONER GÄLLANDE MÖBLER AV TRÄ ELLER TRÄKOMPOSIT SÅSOM MELAMIN, LAMINAT ELLER FANER! Torka rent med en fuktig trasa. Använd endast vatten eller ett mildt rengöringsmedel. Torka torrt med en ren trasa.</p>
<p>NO: GENERELLE INSTRUKSJONER FOR MRBLER LAGET AV TRE ELLER TREKOMPOSITT SOM MELAMIN, LAMINAT ELLER FINER! Tjrk av med en fuktig klut. Bruk bare vann eller et mildt vaskemiddel. Tjrk av med en ren klut.</p>
<p>FI: YLEISIÄ OHJEITA PUUSTA JA PUUKOMPOSIITTIMATERIAALEISTA KUTEN MELAMIINISTA, LAMINAATISTA TAI VANERISTA VALMISTETUILLE KALUSTEILLE! Pyyhi puhtaaksi kostealla liinalla. Käytä vain vettä tai mietoä pesuainetta. Kuivaa puhtaalla liinalla.</p>
<p>PL: OGÓLNE INSTRUKCJE DOTYCZĄCE MEBLI Z DREWNA ORAZ MATERIAŁÓW DREWNOPOCHODNYCH: MELAMINA, LAMINAT, OKLEINA Do czyszczenia należy używać wilgotnej ściereczki. Używać wyłącznie wody lub delikatnego detergentu. Wycierać do sucha ściereczką.</p>
<p>CZ: OBECNÉ POKYNY TÝKAJÍCÍ SE NÁBYTKU VYROBENÉHO ZE DŘEVA NEBO Z KOMPOZITŮ DŘEVA, NAPŘ. S POVRCHEM Z MELAMINU, LAMINÁTU NEBO DÝHY! Čistěte otřením navlhčeným hadříkem. Používejte pouze vodu nebo jemný čistící prostředek. Vytřete dosucha čistým hadříkem.</p>
<p>HU: ÁLTALÁNOS ÚTMUTATÁS A FÁBÓL KÉSZÜLT VAGY ÖSSZETETT FAANYAGOT, PÉLDÁUL MELAMIN-, LAMINÁLT VAGY FURNÉRFELÜLETET TARTALMAZÓ BÚTOROKHOZ Törölje tisztára nedves ruhával. Csak vizet vagy kímélő tisztítószert használjon. Törölje szárazra tiszta ruhával.</p>
<p>SK: VŠEOBECNÉ POKYNY PRE NÁBYTKOVÝCH POUŽÍVATEĽOV, NAPRIKLAD MELAMINU, LAMINÁTU ALEBO PREGLEJKOVÝCH POVRCHOV! Utrite dočista navlhčenou utierkou. Používajte iba vodu alebo jemný čistiaci prostriedok. Utrite dosucha čistou utierkou.</p>
<p>NL: ALGEMENE INSTRUCTIES VOOR MEUBELS VERVAARDIGD UIT HOUT OF HOUTCOMPOSIT ALS MELAMINE, LAMINAAT OF FINEEROPPERVLAKKEN! Reinig met een vochtige doek. Gebruik alleen water of wasmiddel. Droogwrijven met een schone doek.</p>
<p>SI: SPLOŠNA NAVODILA ZA VZDRŽEVANJE POHIŠTVA IZ LESA ALI LESENIH KOMPOZITOV, KOT SO MELANIN, LAMINAT ALI FURNIR! Obrišite z vlažno krpo. Uporabljajte le vodo ali blag detergent. Posušite s čisto krpo.</p>
<p>RU: ОБЩИЕ УКАЗАНИЯ ОТНОСИТЕЛЬНО МЕБЕЛИ, ИЗГОТОВЛЕННОЙ ИЗ ДЕРЕВА ИЛИ ДРЕВЕСНЫХ КОМПОЗИЦИОННЫХ МАТЕРИАЛОВ, ТАКИХ КАК МЕЛАМИН, ЛАМИНАТ ИЛИ ШПОН! Очистите изделие чистой влажной тканью. Используйте мягкодействующее моющее средство. Вытрите досуха чистой тряпкой.</p>
<p>HR: OPĆE UPUTE ZA NAMJEŠTAJ IZRAĐEN OD DRVA ILI DRVNIH KOMPOZITA, KAO ŠTO SU POVRŠINE OD MELAMINA, LAMINATA ILI FURNIRA! Očistite vlažnom krpom. Upotrijebite samo vodu ili blagi deterđent. Posušite čistom krpom.</p>
<p>BA: OPŠTA UPUTSTVA ZA NAMJEŠTAJ OD DRVETA ILI DRVENIH KOMPOZITA, NA PRIMJER ZA POVRŠINE OD MELAMINA, LAMINATA ILI FURNIRA. Obrisati vlažnom krpom. Koristiti samo vodu ili blagi deterđent. Posušiti suhom krpom.</p>
<p>CN: 针对实木及实木复合类（三聚氰胺面、层板、胶合板）家具的一般说明 请用湿布擦拭。只使用水或温和洗涤剂。 请用干净的布擦干。</p>
<p>RS: OPŠTA UPUTSTVA ZA NAMEŠTAJ NAPRAVLJEN OD DRVETA ILI DRVENOG KOMPOZITA KAO ŠTO SU MELAMIN, LAMINAT ILI FURNIR POVRŠINE! Obrišite vlažnom krpom. Koristite samo vodu ili blagi deterđent. Prebrišite suvom, čistom krpom.</p>
<p>UA: ЗАГАЛЬНА ІНСТРУКЦІЯ ДЛЯ МЕБЛІВ, ВИГОТОВЛЕНИХ З ДЕРЕВА ЧИ ДЕРЕВ'ЯНИХ КОМПОНЕНТІВ, НАПРИКЛАД, МЕЛАМІНУ, ЛАМІНАТА АБО ШПОНУ. Протирайте за допомогою вологої ганчірки. Використовуйте воду або слабкий розчин м'якого засобу. Витирайте чистою ганчіркою.</p>
<p>RO: ÎNSTRUCȚIUNI GENERALE PENTRU PIESELE DE MOBILIER REALIZATE DIN LEMN SAU DIN COMPUȘI DIN LEMN PRECUM SUPRAFEȚELE MELAMINATE, LAMINATE SAU FURNIRUTE! Curățați prin ștergere cu o lavetă umeză. Utilizați numai apă sau un detergent delicat. Uscați prin ștergere cu o lavetă curată.</p>
<p>BG: ОБЩА ИНСТРУКЦИЯ ЗА МЕБЕЛИ, ИЗРАБОТЕНИ ОТ ДЪРВО ИЛИ ДЪРВЕНИ КОМПОЗИТНИ МАТЕРИАЛИ, КАТО МЕЛАМИН, ЛАМИНАТ ИЛИ ФУРНИРНИ ПОВЪРХНОСТИ! Избършете с влажна кърпа. Използвайте само вода или лек почистващ препарат. Подсушете с чиста кърпа.</p>
<p>GR: ΓΕΝΙΚΕΣ ΟΔΗΓΙΕΣ ΓΙΑ ΕΠΙΠΛΑ ΑΠΟ ΞΥΛΟ Ή ΣΥΝΘΕΤΙΚΟ ΞΥΛΟ ΟΠΩΣ ΜΕΛΑΜΙΝΗ, ΛΑΜΙΝΕΪΤ Ή ΛΟΥΣΤΡΑΡΙΣΜΕΝΕΣ ΕΠΙΦΑΝΕΙΕΣ! Σκουπίζετε με ένα υγρό πανί. Χρησιμοποιείτε μόνο νερό ή ένα ήπιο απορρυπαντικό. Στεγνώνετε με ένα καθαρό πανί.</p>
<p>TR: AHŞAP VEYA MELAMİN, LAMİNAT YA DA AHŞAP KAPLAMA GİBİ AHŞAP TÜREVİ YÜZEYLERDEN YAPILAN MOBİLYALARA YÖNELİK GENEL YÖNERGE! Nemli bir bezle silerek temizleyin. Yalnızca su veya yumuşak bir deterjan kullanın. Temiz bir bezle silerek kurulayın.</p>
<p>FR: INSTRUCTIONS GÉNÉRALES POUR LE MOBILIER CONSTITUÉ DE BOIS OU DE COMPOSITES DE BOIS (COMME LES SURFACES EN MELAMINÉ, STRATIFIÉ OU PLACAGE) Nettoyer à l'aide d'un chiffon humide. Utiliser uniquement de l'eau ou un détergent doux. Essuyer à l'aide d'un chiffon propre.</p>

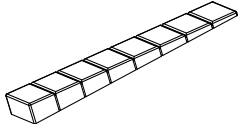
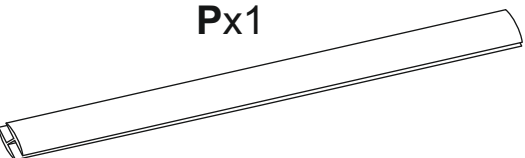
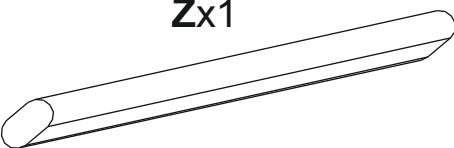
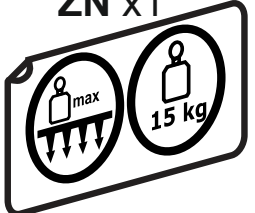
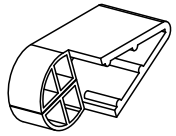
<p>Ax8</p>  <p>Ø7x50 mm</p>	<p>Bx3</p> 		<p>BAx6</p> 	
<p>BFx6</p> 	<p>Cx42</p>  <p>Ø3,5x16 mm</p>	<p>C1x2</p> 	<p>Dx1</p> 	<p>D1x15</p> 
<p>Ex5</p> 	<p>E1x6</p>  <p>Ø6,3x13 mm</p>	<p>Fx10</p>  <p>4x 27 mm</p>	<p>Ix32</p>  <p>Ø8x35 mm</p>	<p>Jx18</p>  <p>15x13 mm</p>
<p>Kx18</p>  <p>43 mm</p>	<p>Lx8</p> 	<p>N1x73</p>  <p>1,2x25</p>	<p>Tx16</p> 	<p>Yx2</p> 
<p>OBx4</p> 				<p>FA x2</p> 
<p>Px1</p>  <p>1652 mm</p>		<p>Zx1</p>  <p>925 mm</p>		<p>ZN x1</p> 
<p>Ux1</p> 				

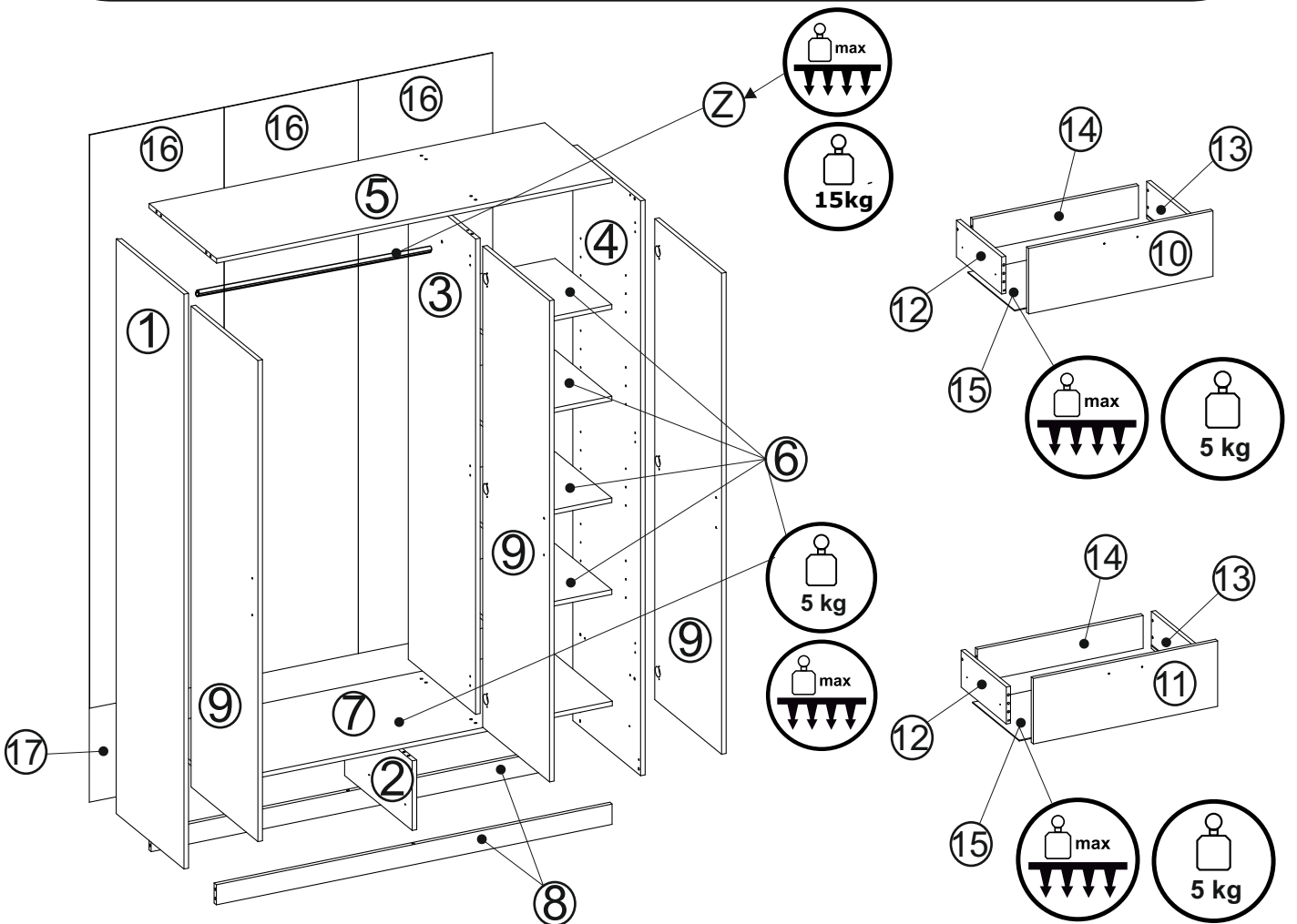
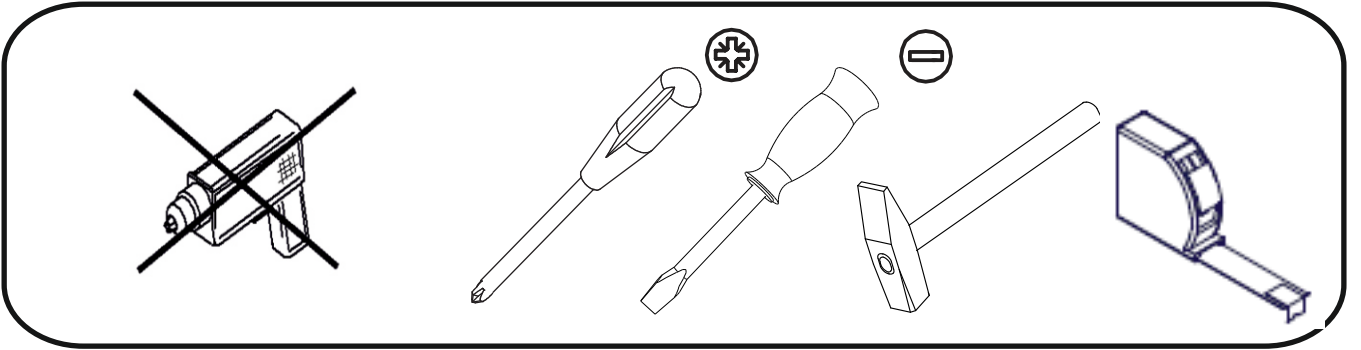

BOX 1

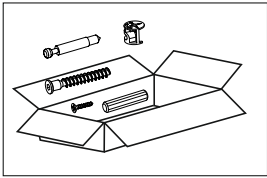

455x400x16 mm

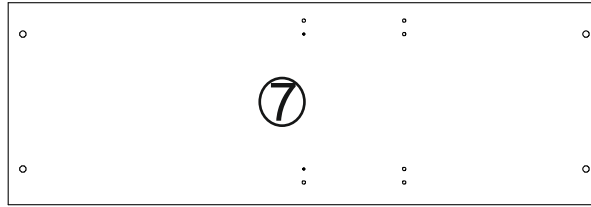

1402x479x16 mm



350x140x16mm

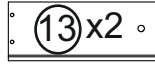

350x140x16mm

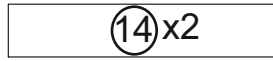

640x125x16 mm

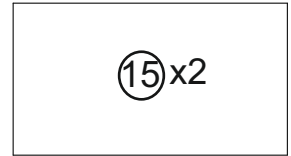

650x357x3 mm

BOX 2

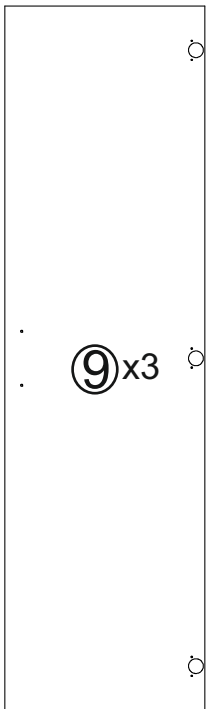

1671x474x16 mm

BOX 3

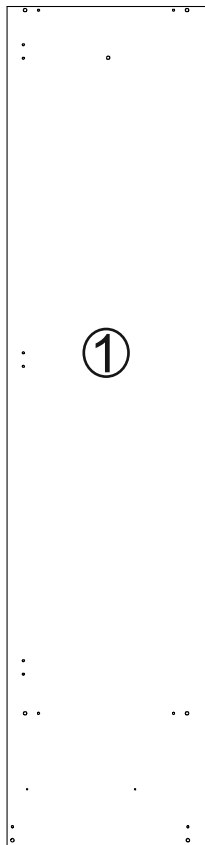

1997x483x16 mm

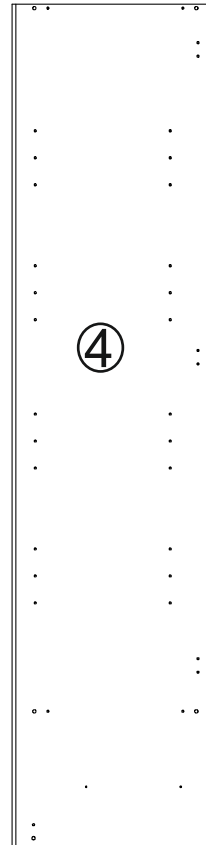

1997x483x16 mm

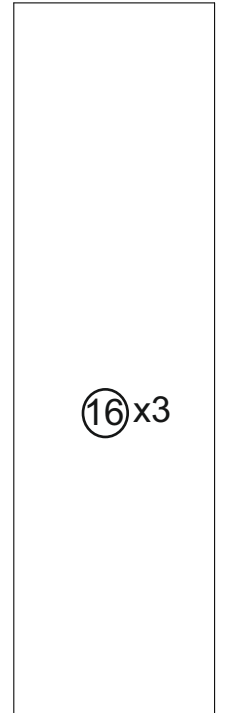

1674x473x3 mm



250x1421x3 mm

BOX 4



242x478x16 mm

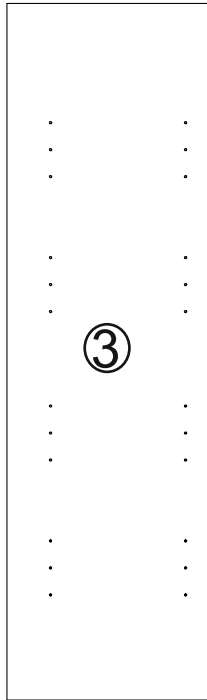

1652x478x16 mm

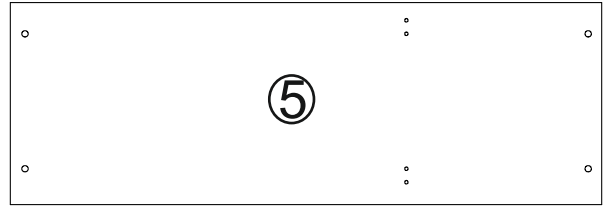

1402x479x16 mm

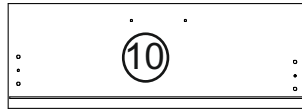

712x248x16 mm

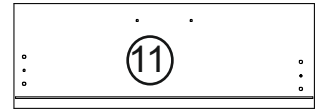

712x248x16 mm



1402x70x16 mm

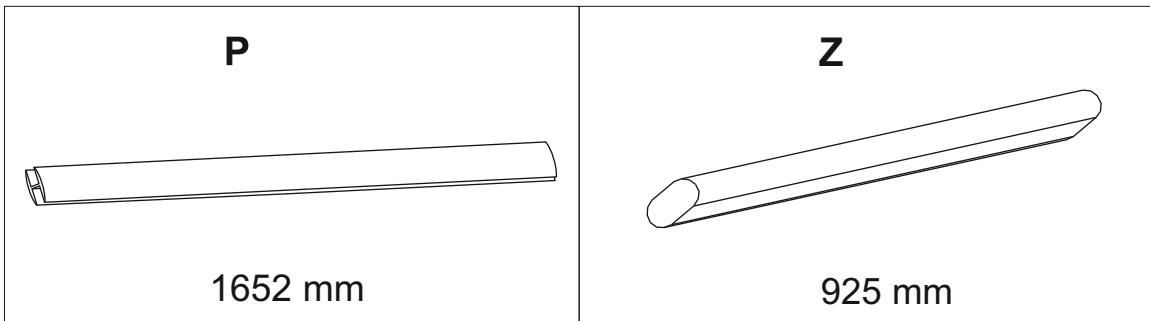

1

Bx3 	Ix4  Ø8x35 mm	E1x6  Ø 6,3x13 mm	
-------------------------------------------------------------------------------------------------	-------------------------------------------------------------------------------------------------------------	-----------------------------------------------------------------------------------------------------------------	-------------------------------------------------------------------------------------

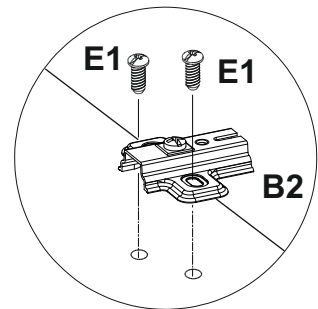
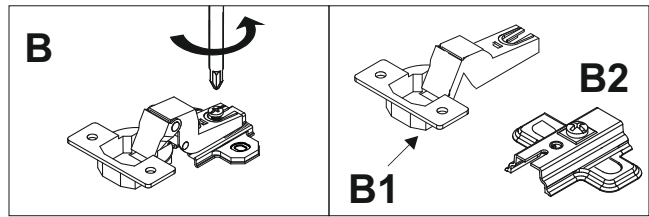
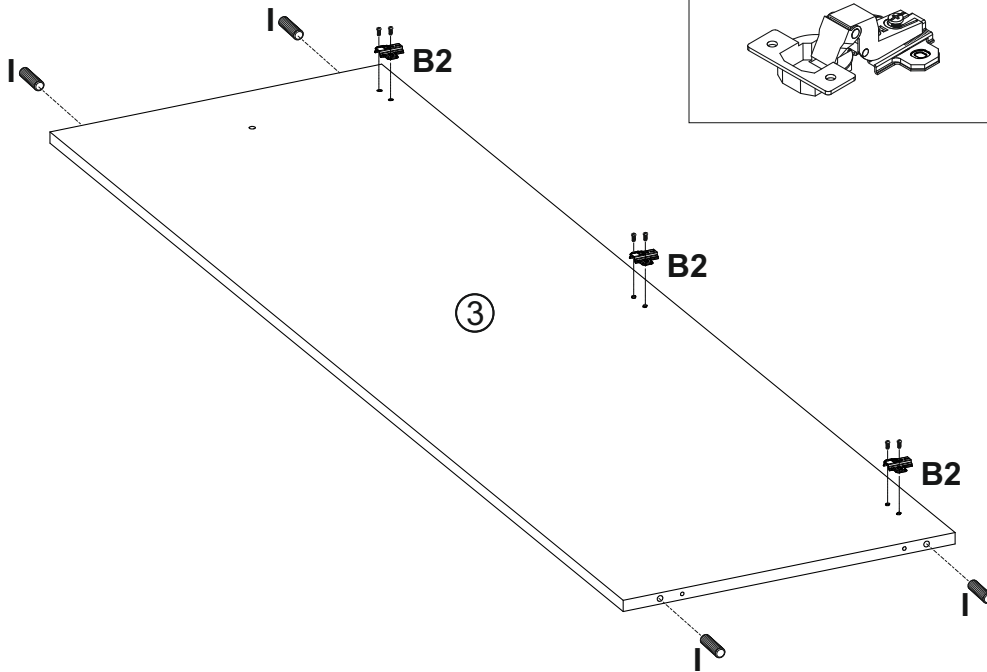

2

Cx1  Ø 3,5x16 mm	C1x1 	Tx8 	
------------------------------------------------------------------------------------------------------------------	----------------------------------------------------------------------------------------------------	---------------------------------------------------------------------------------------------------	---------------------------------------------------------------------------------------

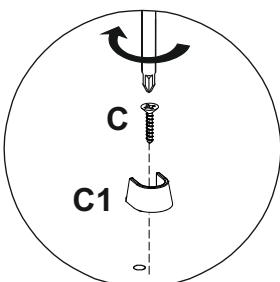
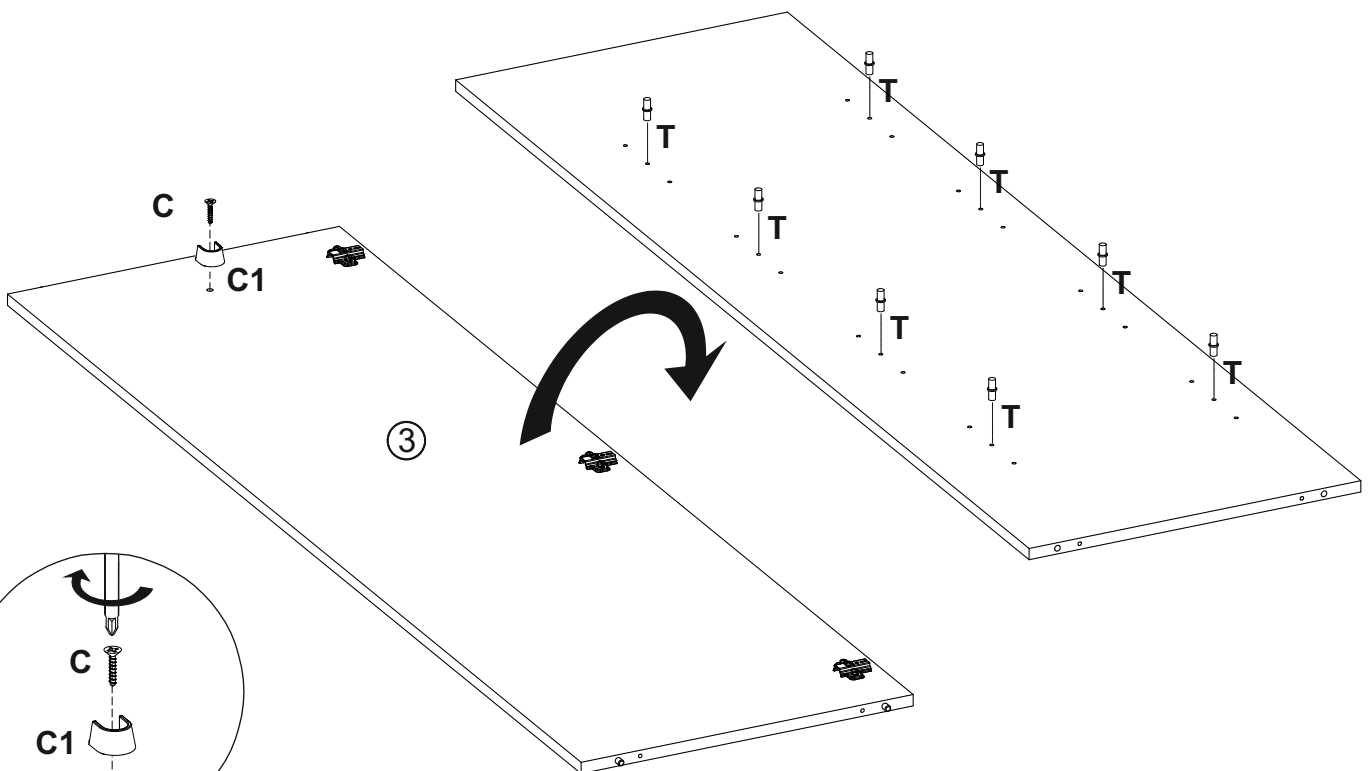

3

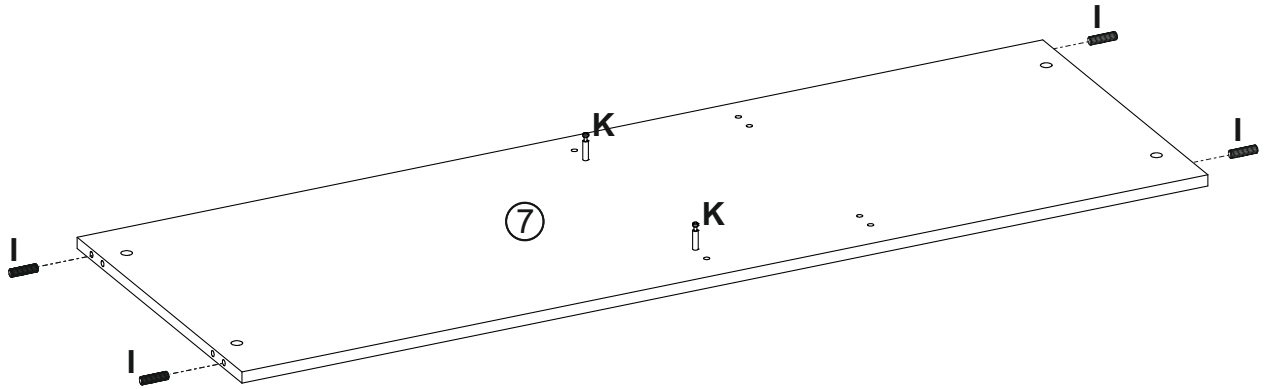

4

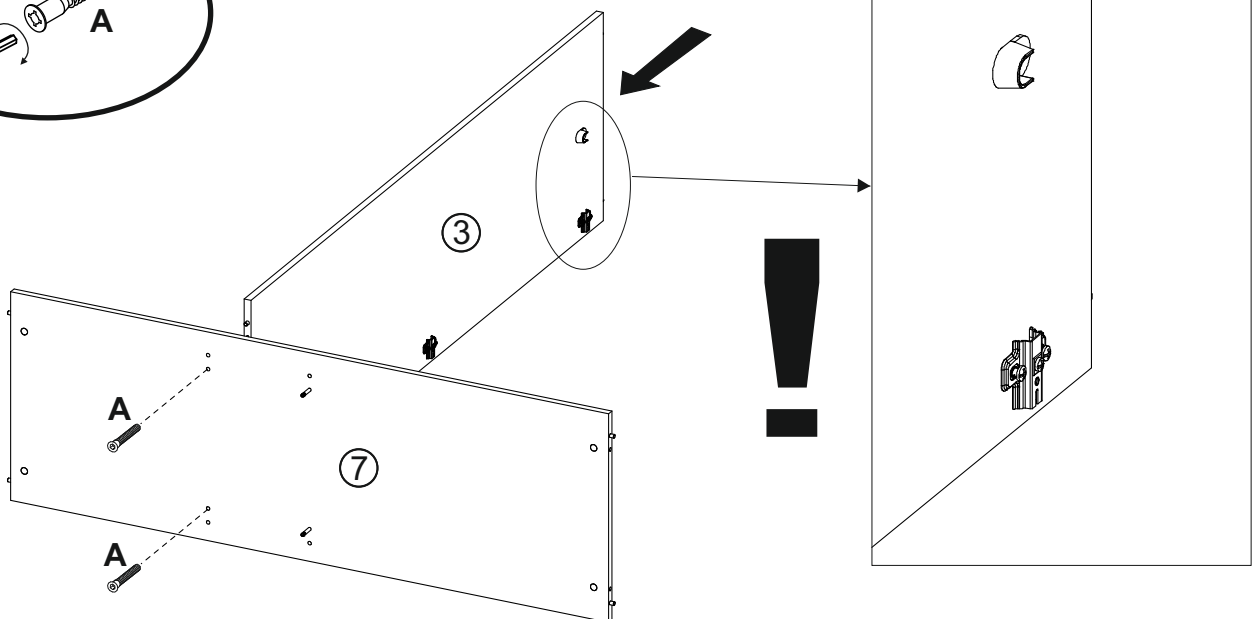
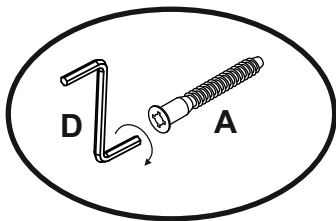

5

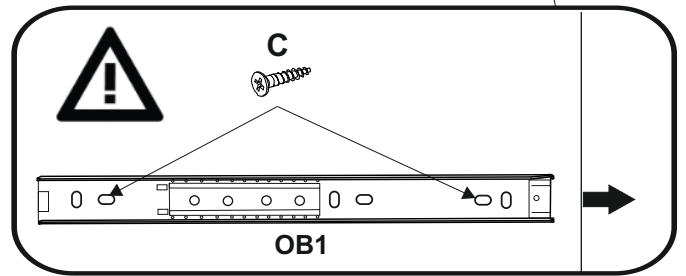
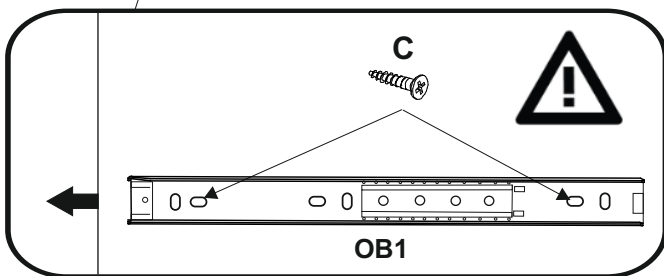
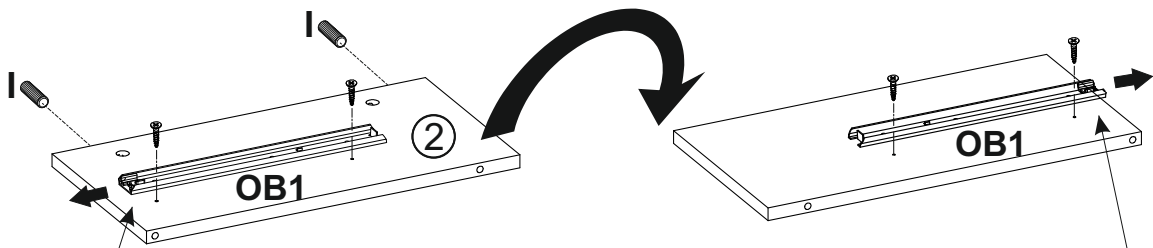
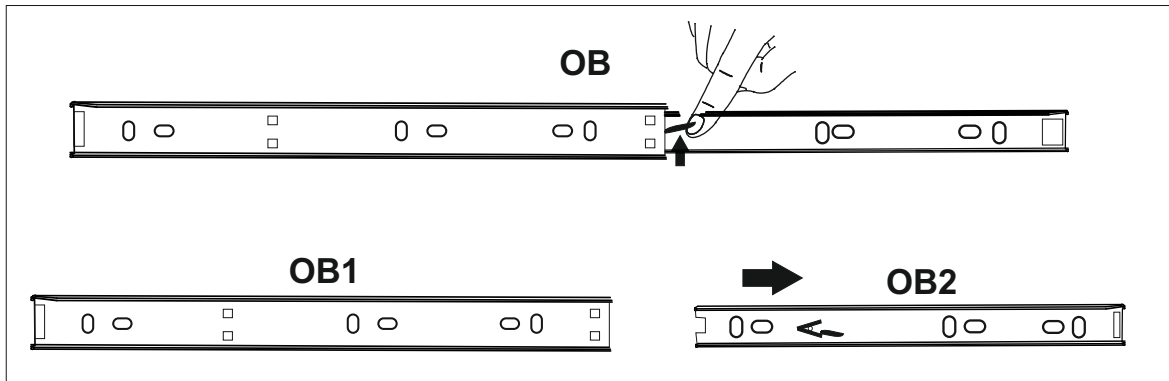

6

Jx2
15x13 mm

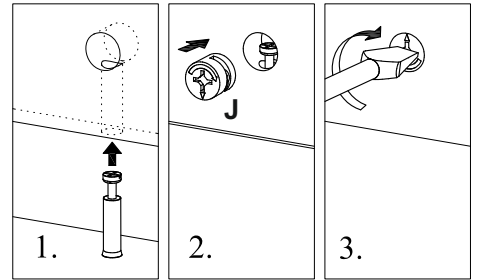
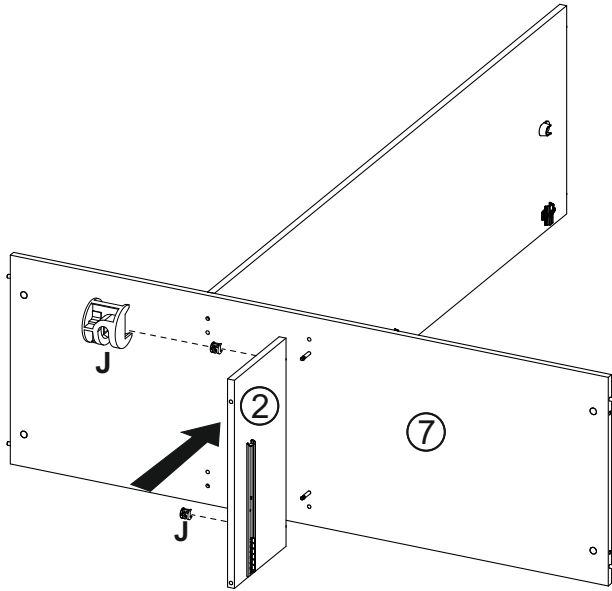
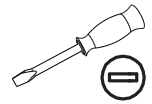

7

Ix4
∅8x35 mm

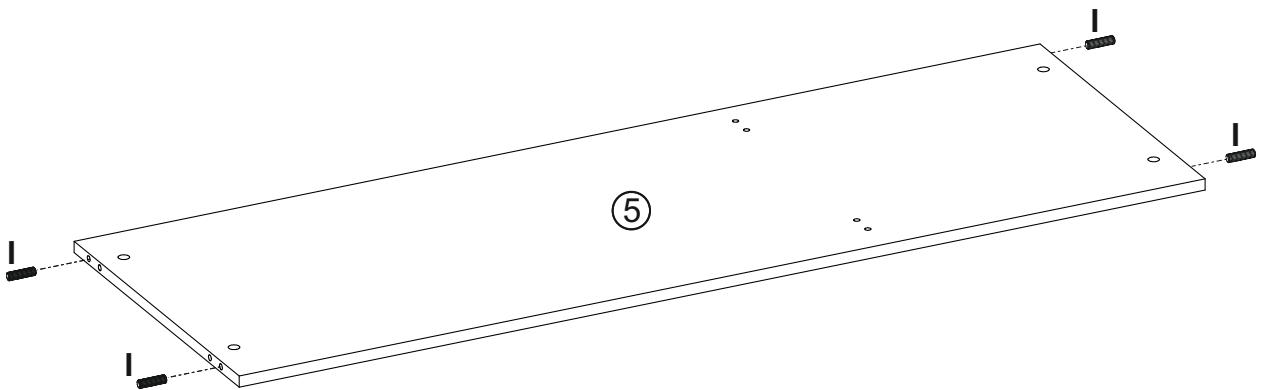
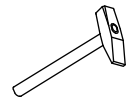

8

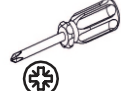
 Cx2 ∅3,5x16 mm	 Kx6 43 mm	 OBx1	
--------------------------------------------------------------------------------------------------------	---------------------------------------------------------------------------------------------------	-------------------------------------------------------------------------------------------	-------------------------------------------------------------------------------------

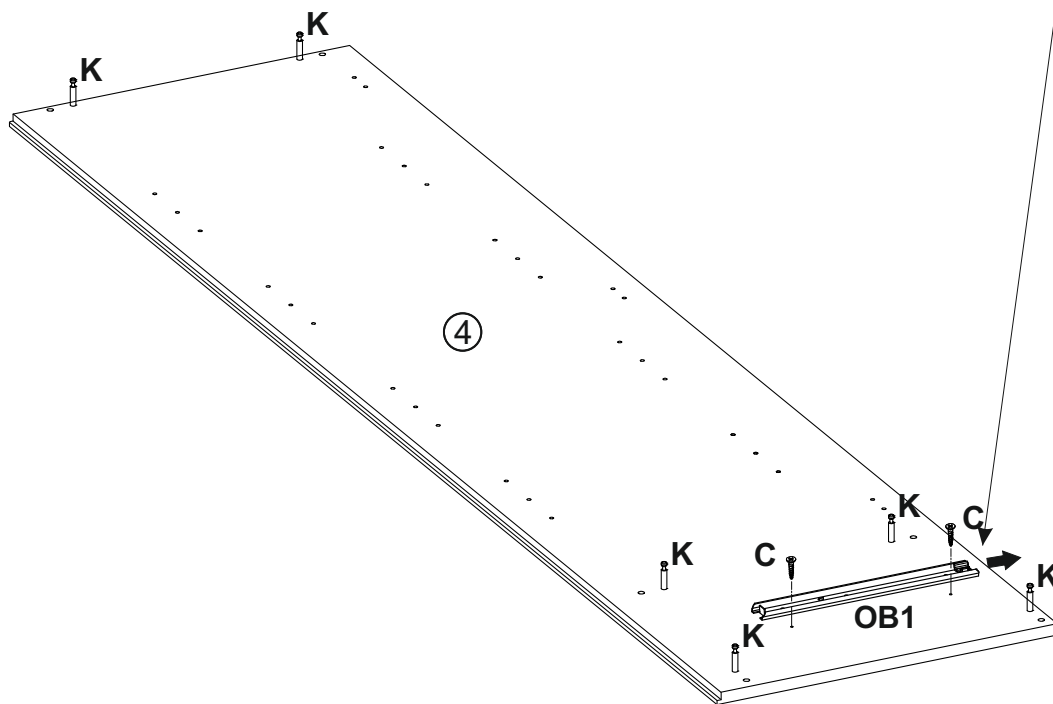
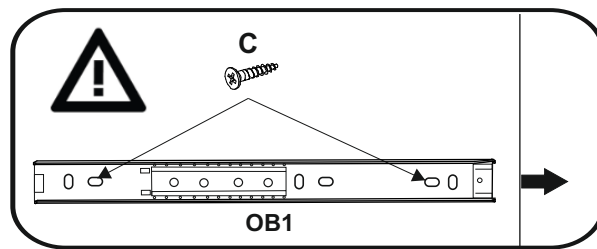
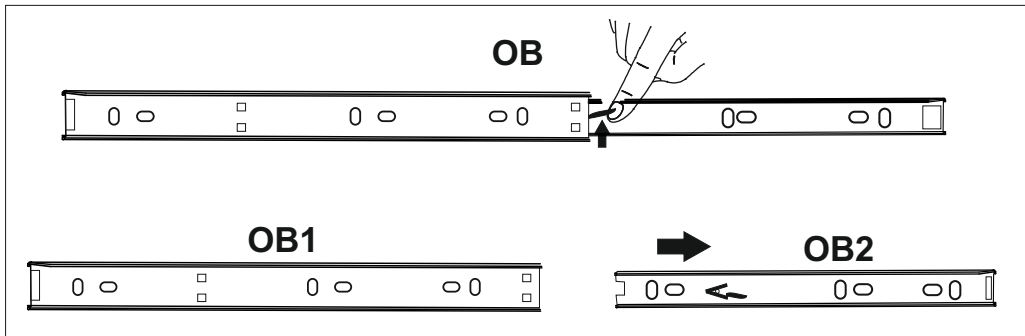

9

BA x3 	BFx2 	Tx8 		
--------------------------------------------------------------------------------------------	-------------------------------------------------------------------------------------------	------------------------------------------------------------------------------------------	--	-------------------------------------------------------------------------------------

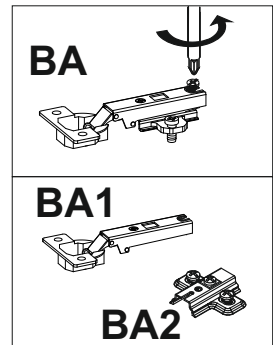
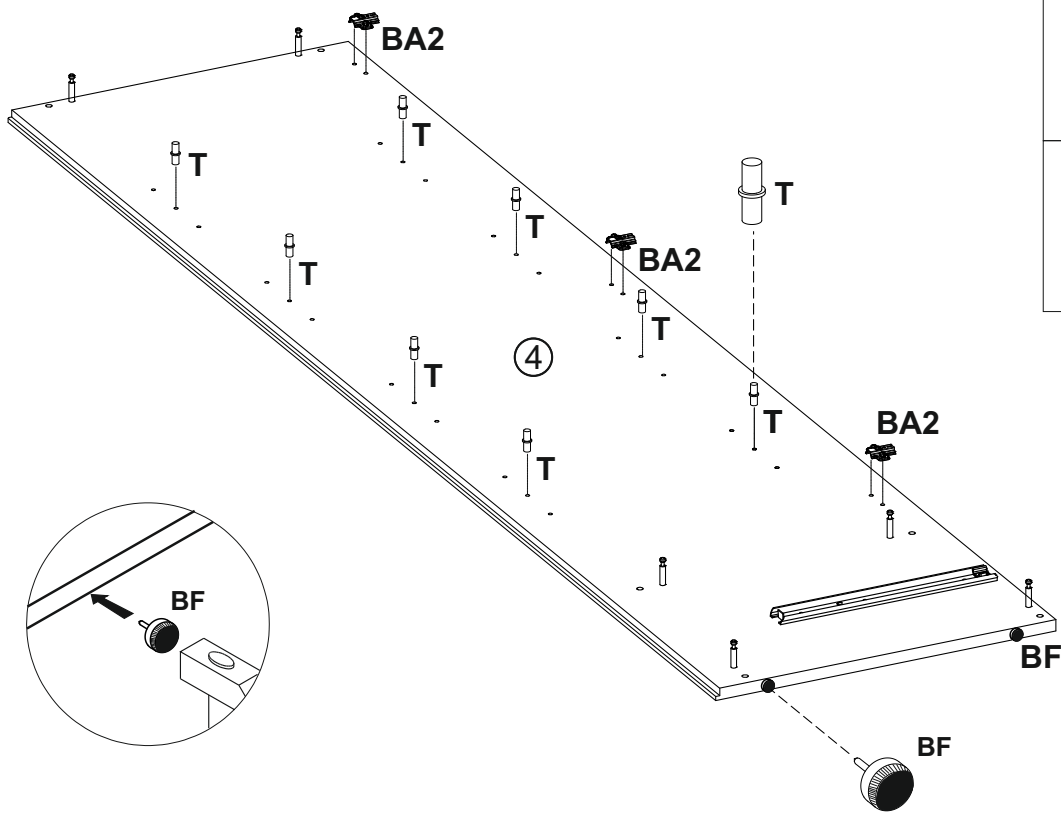

10

Ax2  Ø7x50 mm	Dx1 	Jx4  15x13 mm		
--------------------------------------------------------------------------------------------------------	--------------------------------------------------------------------------------------------	--------------------------------------------------------------------------------------------------------	--	---------------------------------------------------------------------------------------

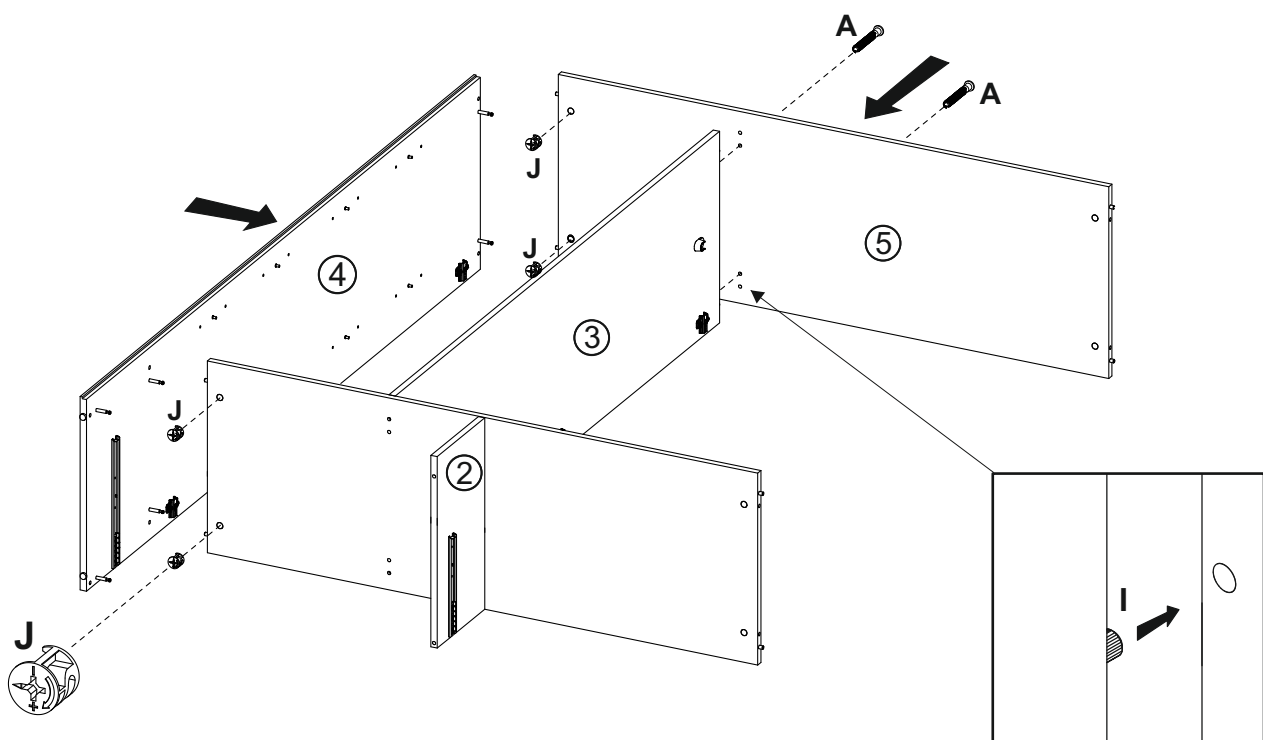

11

BFx2 	Ix6  Ø8x35 mm	
-------------------------------------------------------------------------------------------	------------------------------------------------------------------------------------------------------	-------------------------------------------------------------------------------------

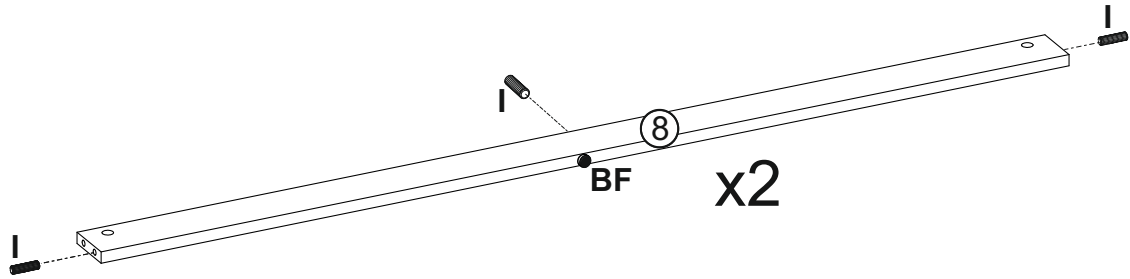

12

Lx2 	Jx2  15x13 mm	
-------------------------------------------------------------------------------------------	-------------------------------------------------------------------------------------------------------	--------------------------------------------------------------------------------------

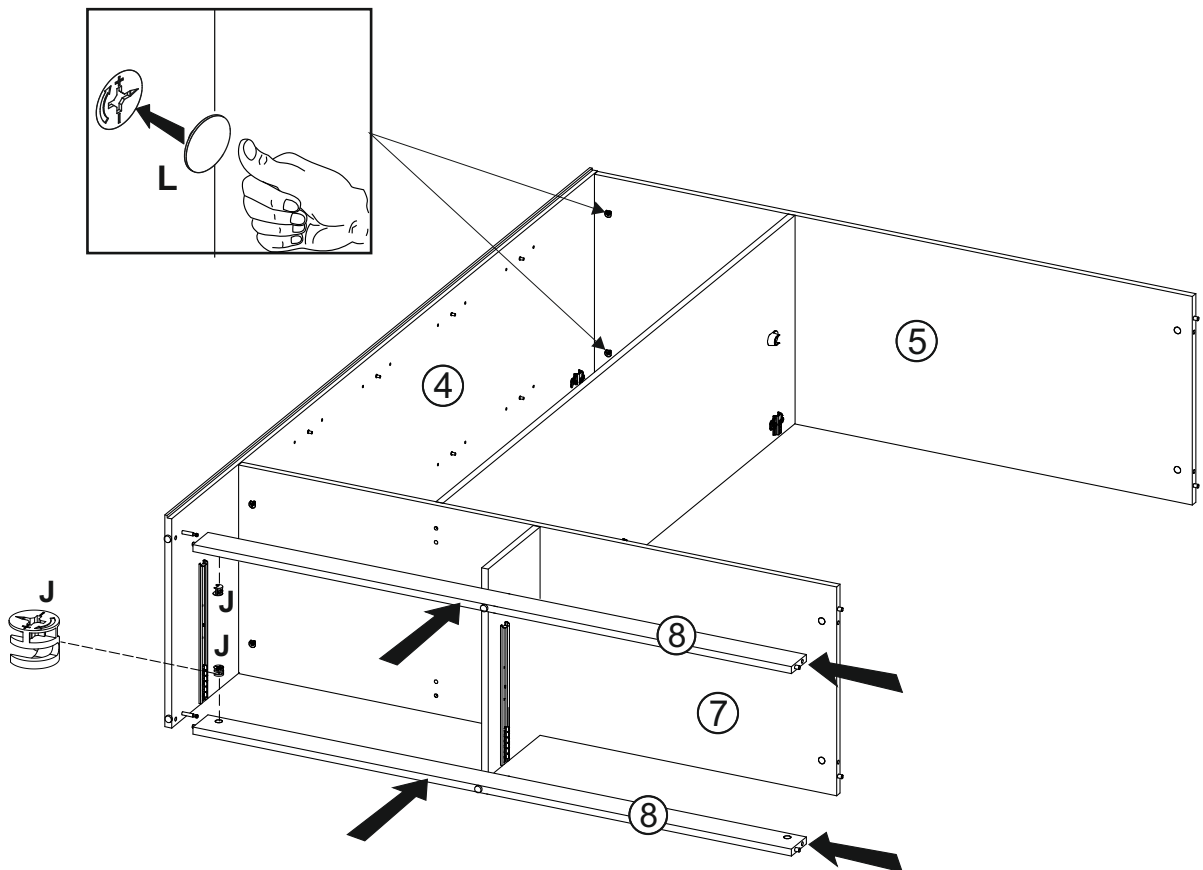

13

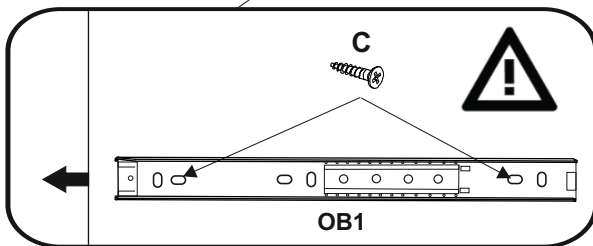
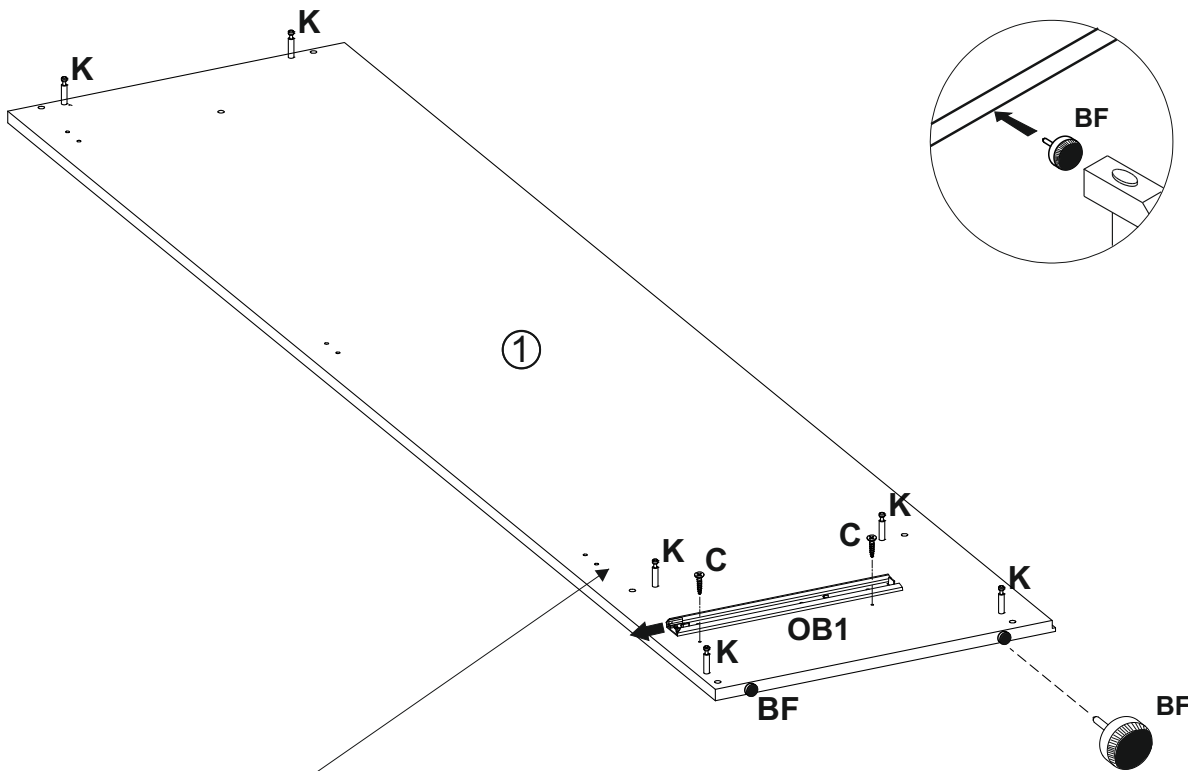
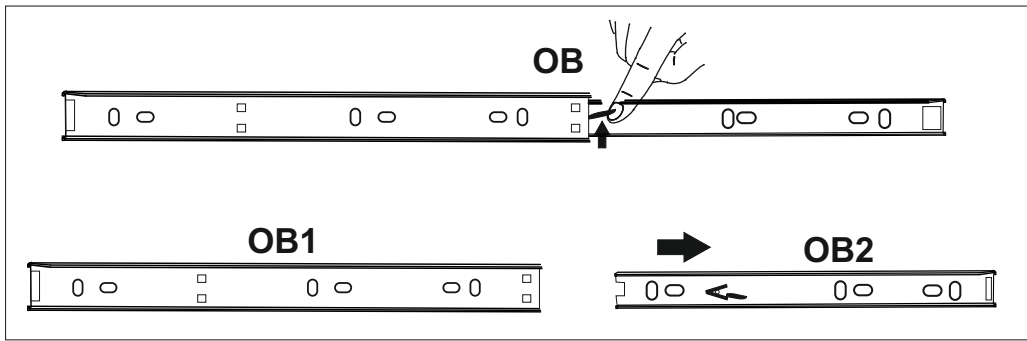
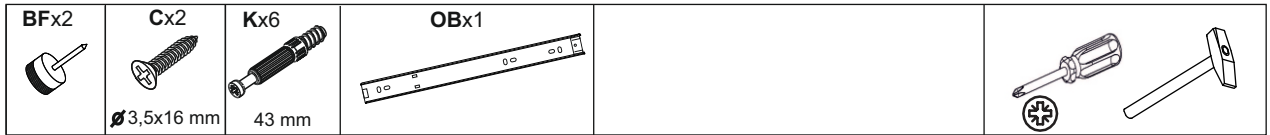

14

BA x3



Cx1



∅3,5x16 mm

C1x1

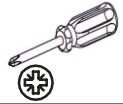

BA

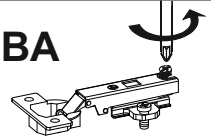

BA1

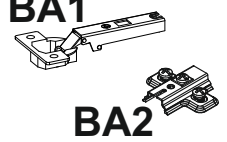

BA2

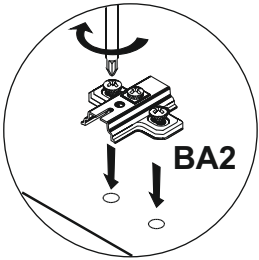
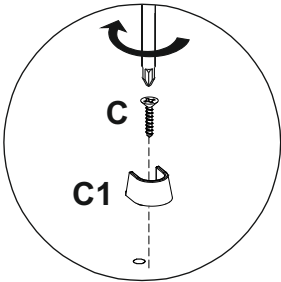
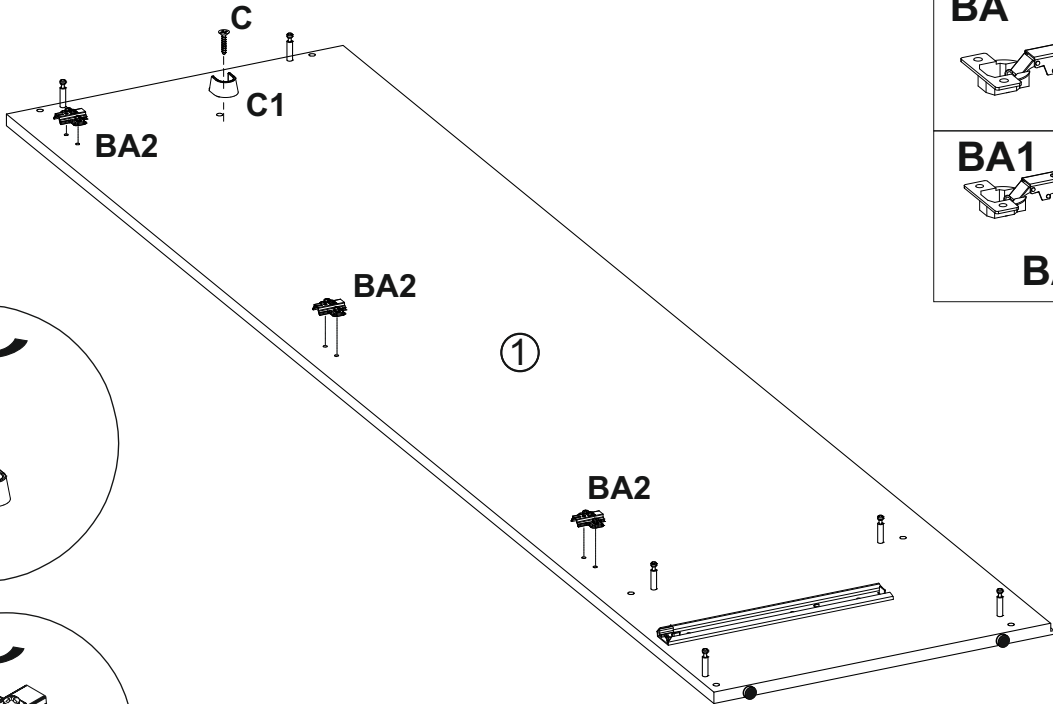

15

Lx2







Jx6

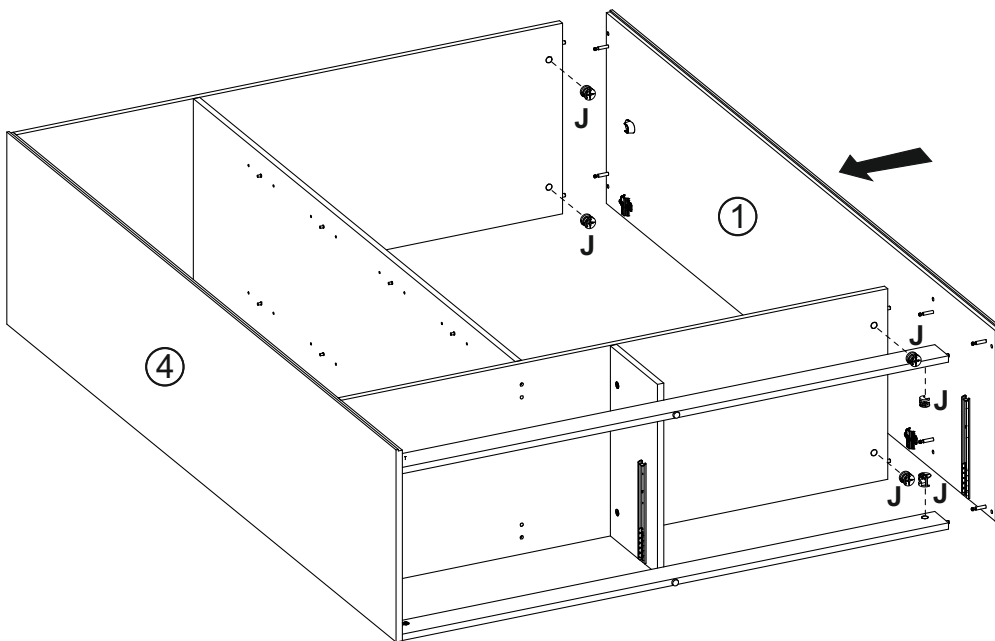
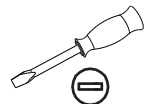

15x13 mm

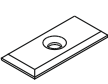

16

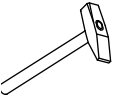
D1x15 	N1x61 1,2x25 	Px1 1652 mm 	Ux1 		
--------------------------------------------------------------------------------------------	------------------------------------------------------------------------------------------------------	-----------------------------------------------------------------------------------------------------	------------------------------------------------------------------------------------------	-------------------------------------------------------------------------------------	-------------------------------------------------------------------------------------

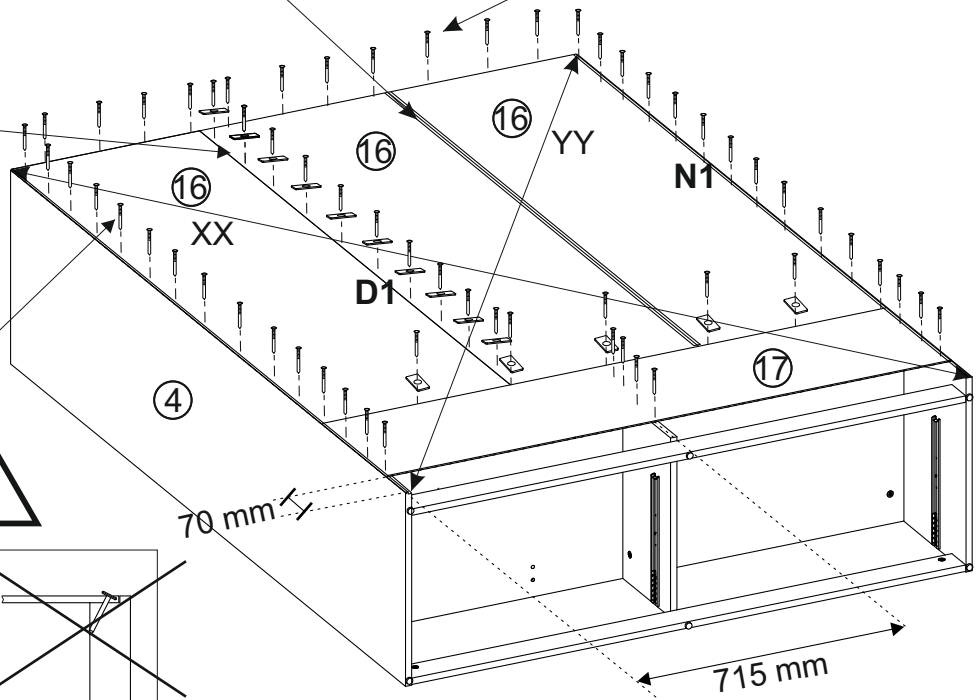
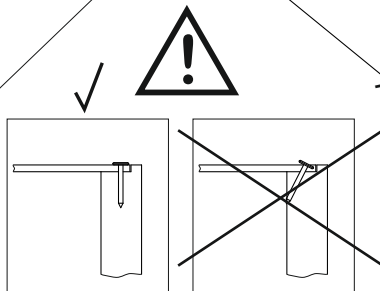
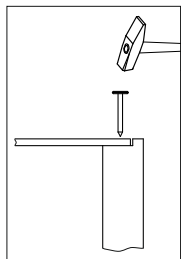
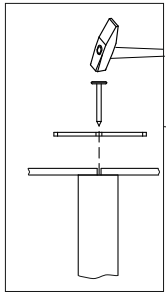
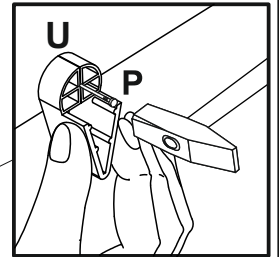
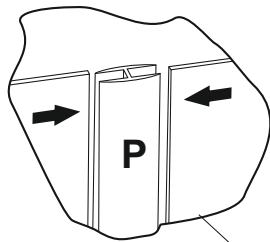
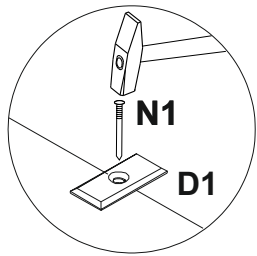
XX=YY=90°**17**

Ix12 ø8x35 mm 	
---------------------------------------------------------------------------------------------------------	---------------------------------------------------------------------------------------

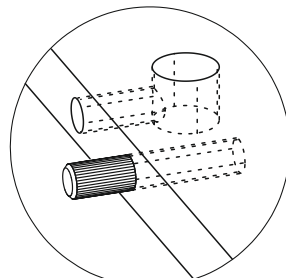
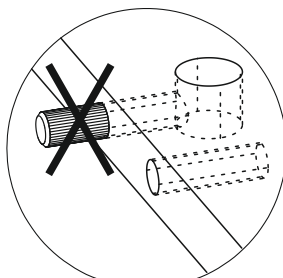
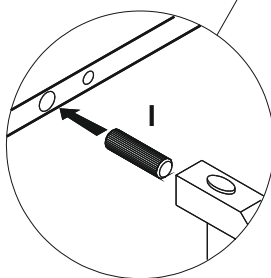
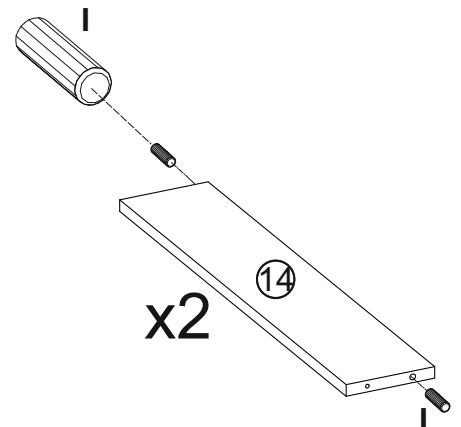
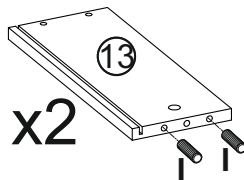
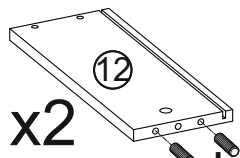

18

Kx4



43 mm

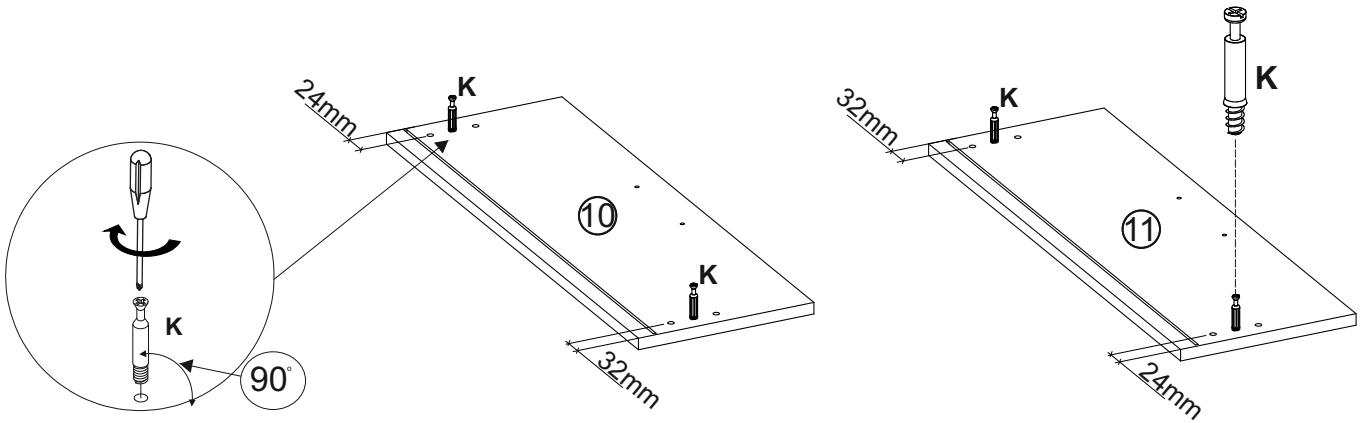
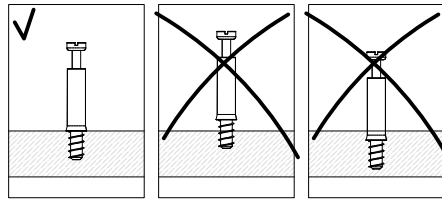
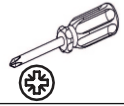

19

Ax4



Ø7x50 mm

Dx1

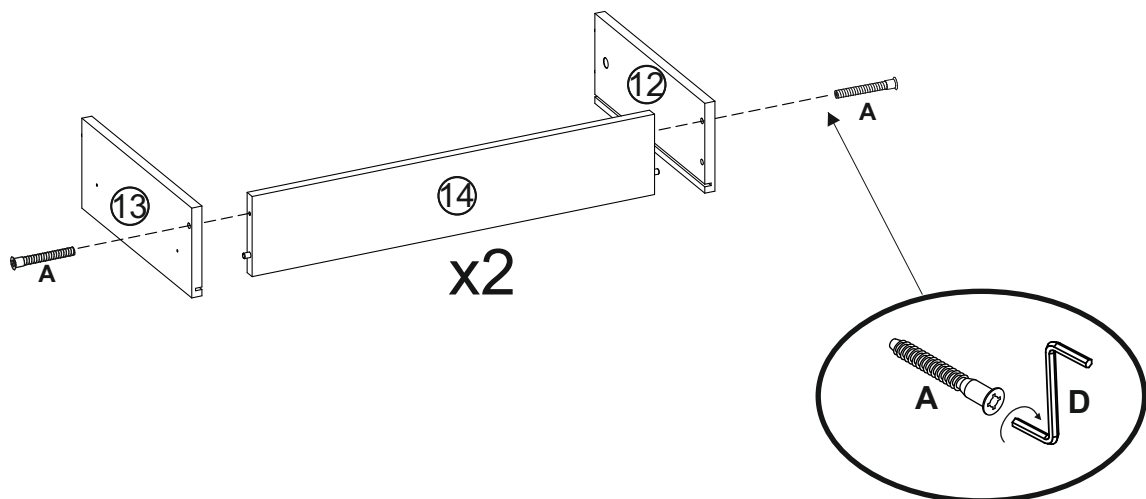

20

Jx4
15x13 mm

Lx4

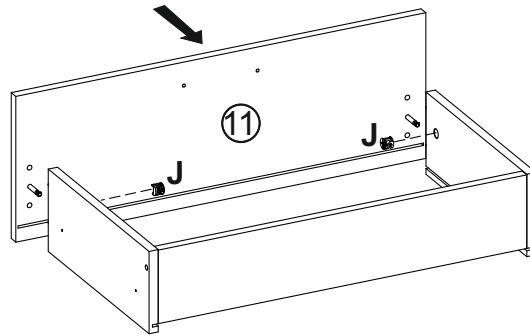
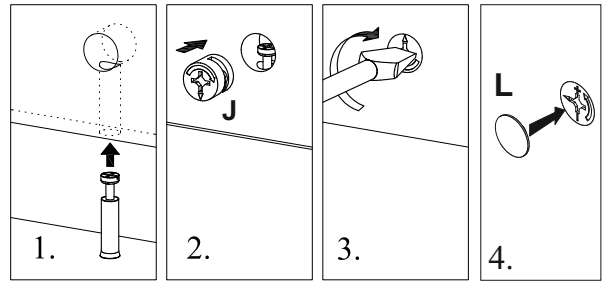
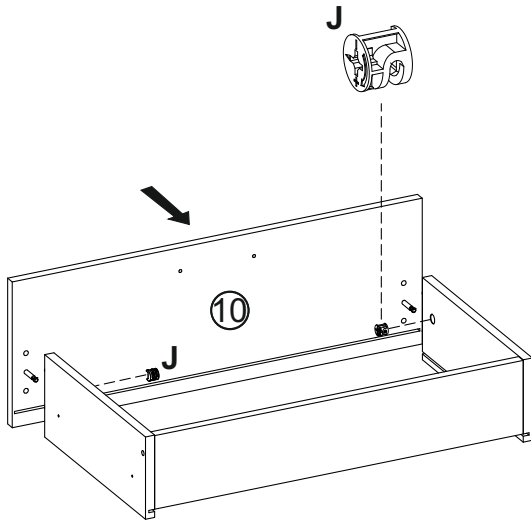
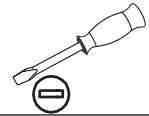

21

N1x12
1,2x25

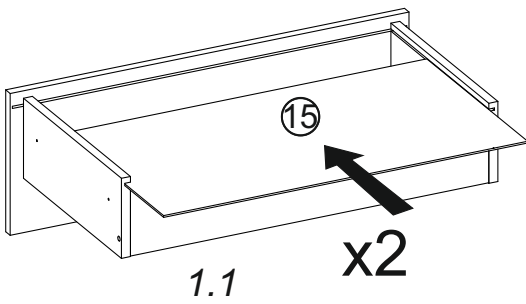
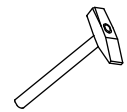

Ux1

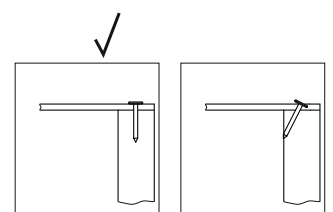
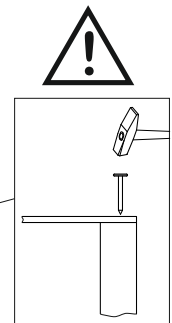
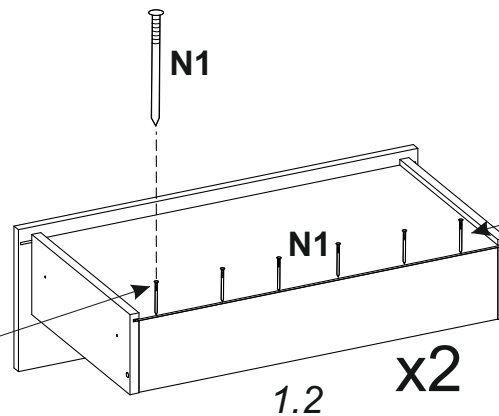
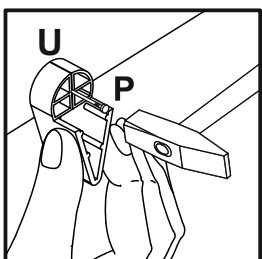
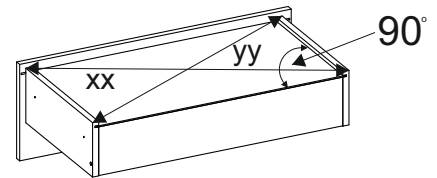

!
xx=yy

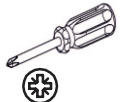

22

Ex2 	Fx4 4x 27 mm 		
------------------------------------------------------------------------------------------	------------------------------------------------------------------------------------------------------	--	-------------------------------------------------------------------------------------

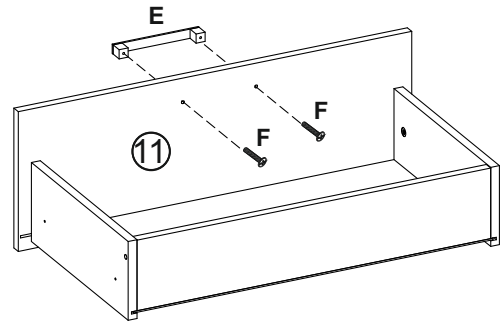
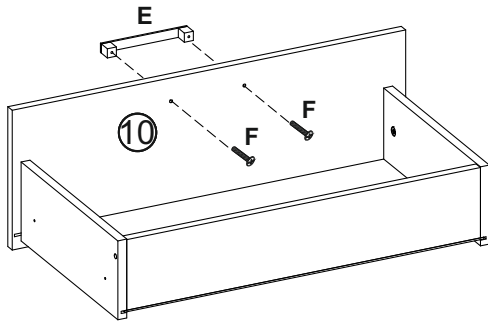

23

Cx8 Ø 3,5x16 mm 	OB2x4 		
----------------------------------------------------------------------------------------------------------	---------------------------------------------------------------------------------------------	--	--------------------------------------------------------------------------------------

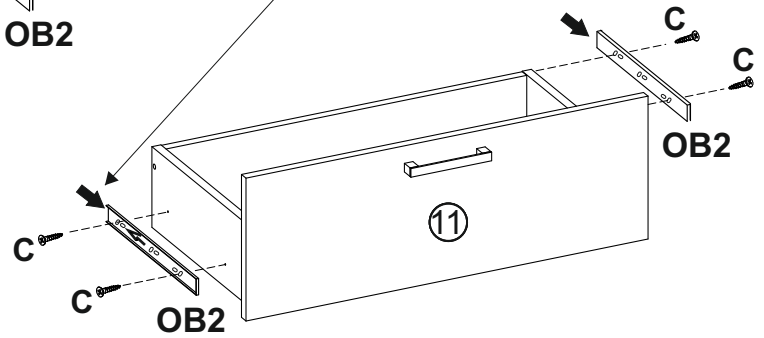
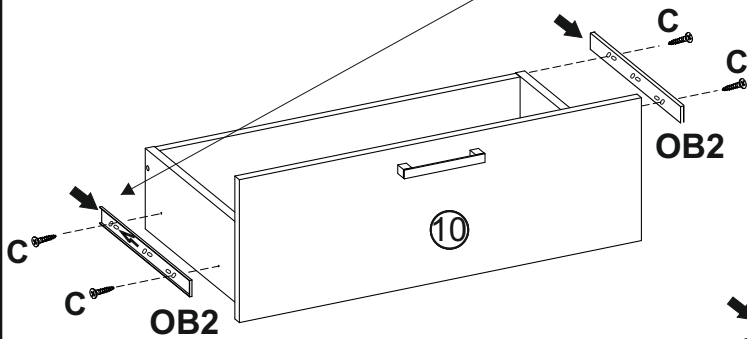
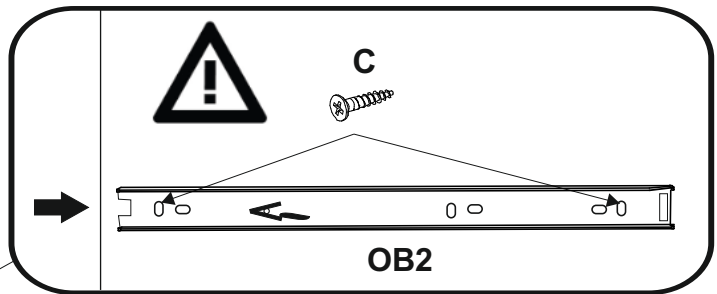

24

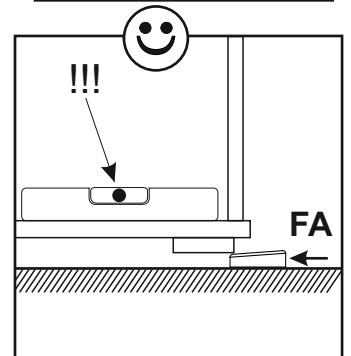
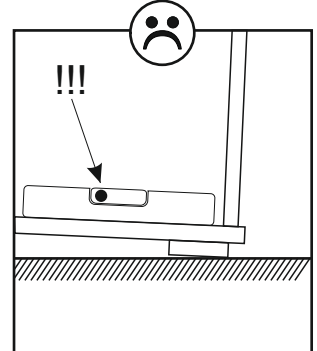
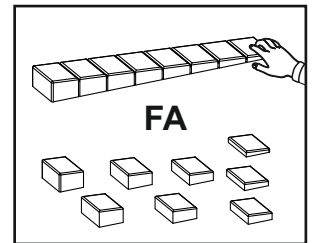
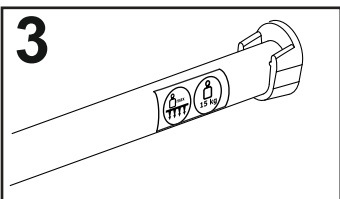
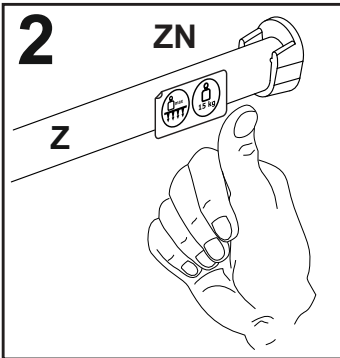
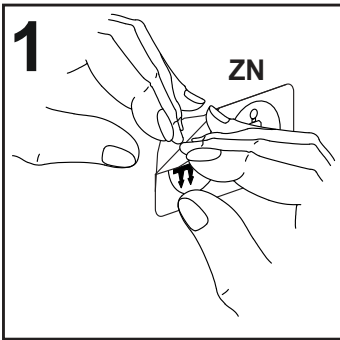
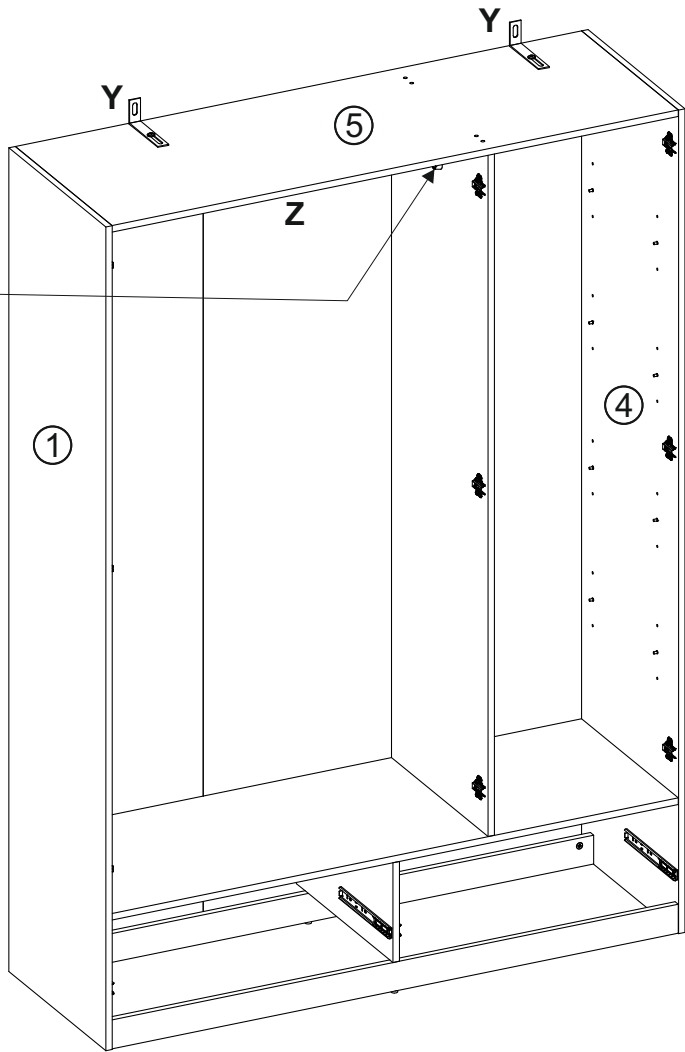
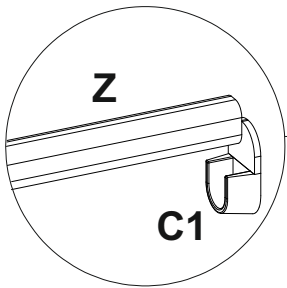
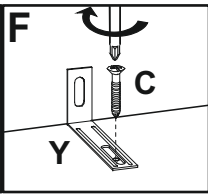
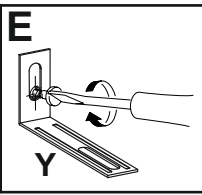
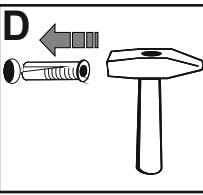
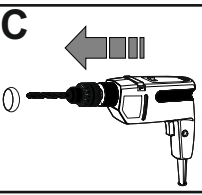
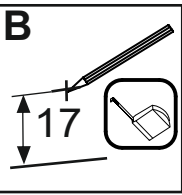
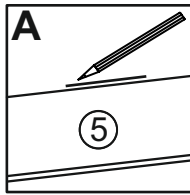
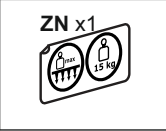
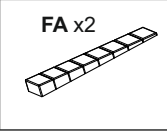
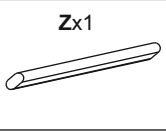

25

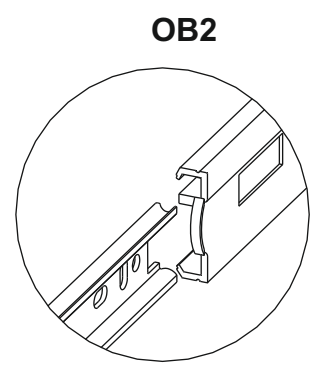
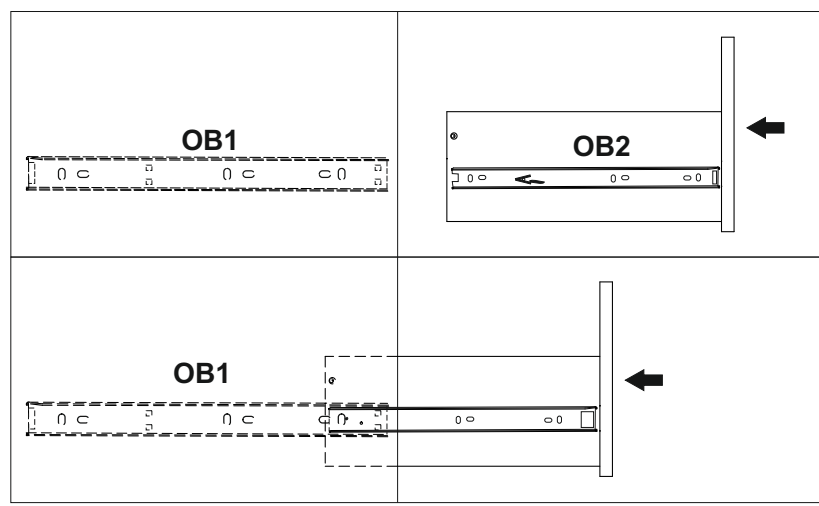
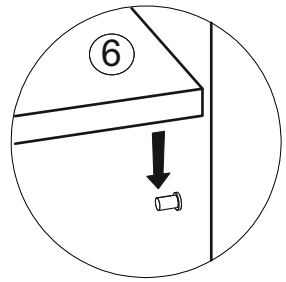
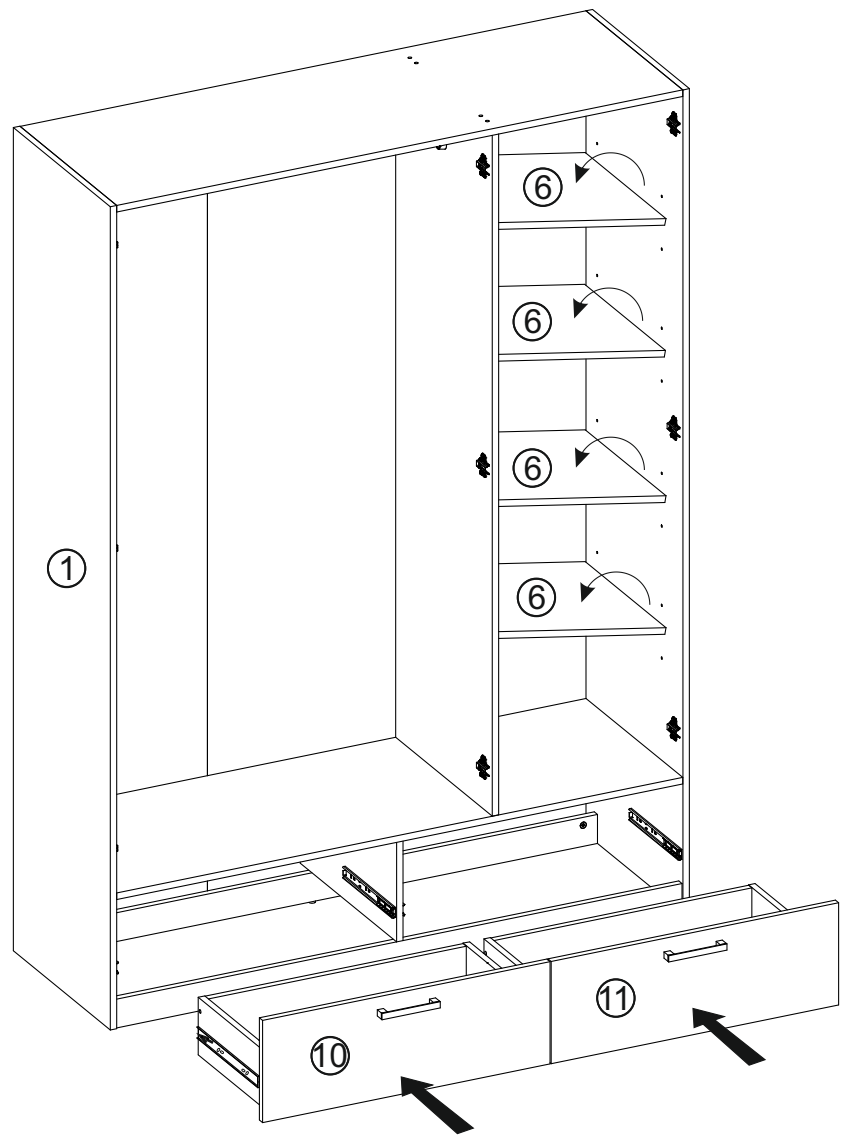
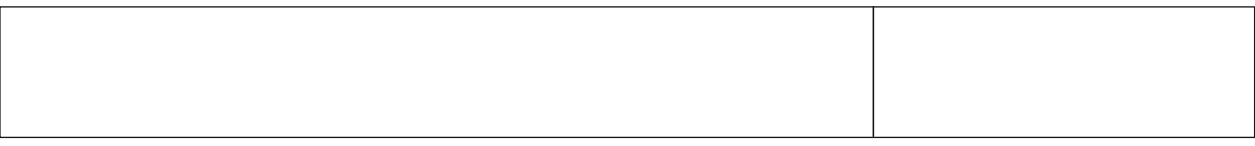

26

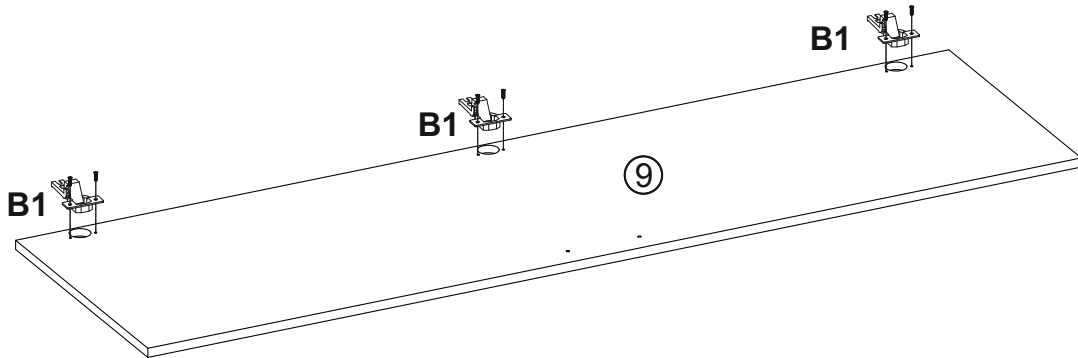
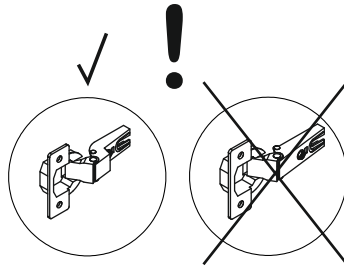
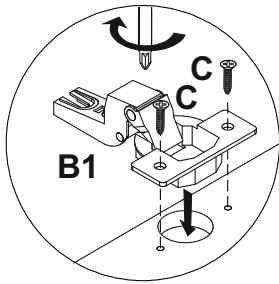
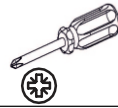
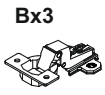

27

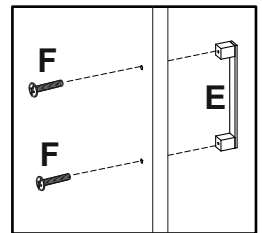
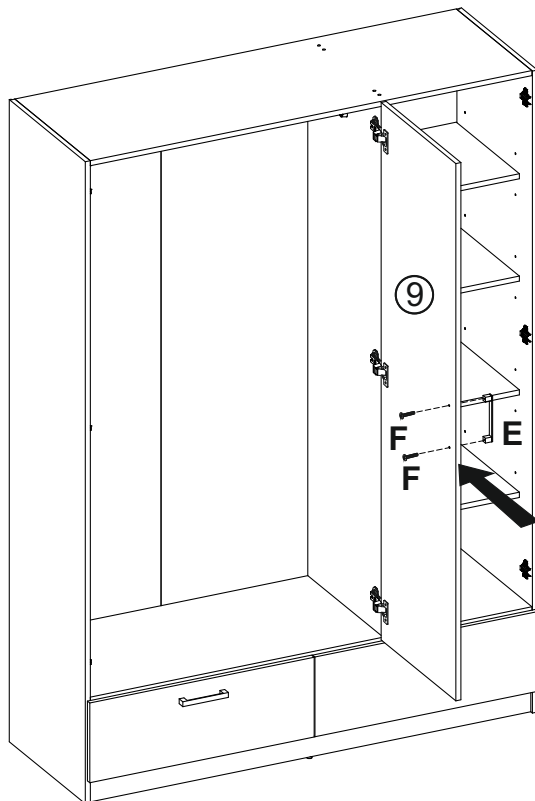
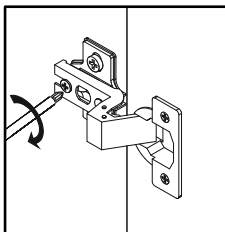
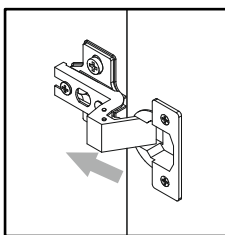
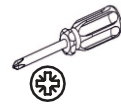
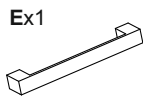

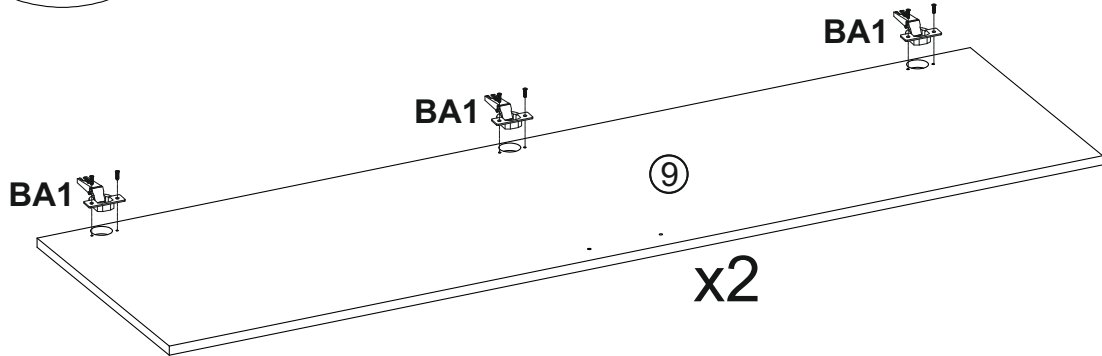
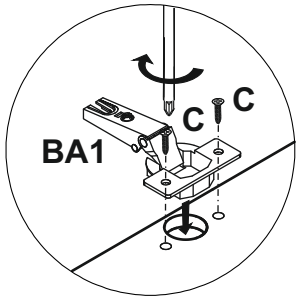

28

BA x6 	Cx6  Ø3,5x16 mm		 
--------------------------------------------------------------------------------------------	--------------------------------------------------------------------------------------------------------	--	----------------------------------------------------------------------------------------------------------------------------------------------------------------------------

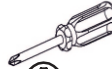

29

Ex2 	Fx4  4x 27 mm		 
--------------------------------------------------------------------------------------------	--------------------------------------------------------------------------------------------------------	--	--------------------------------------------------------------------------------------------------------------------------------------------------------------------------------

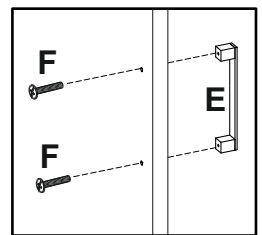
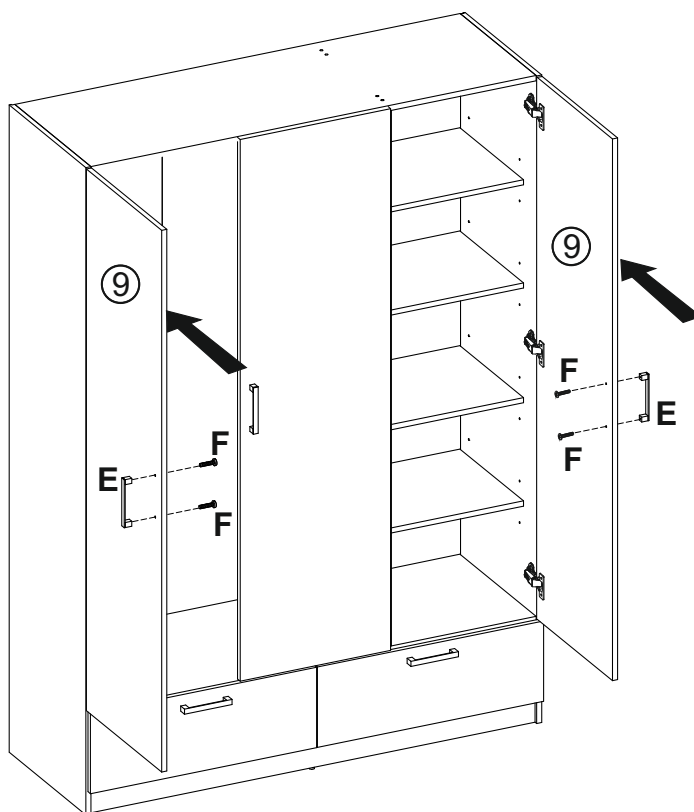
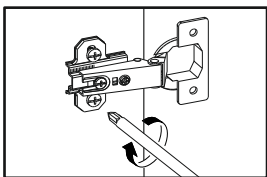
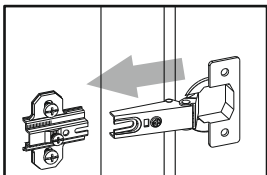

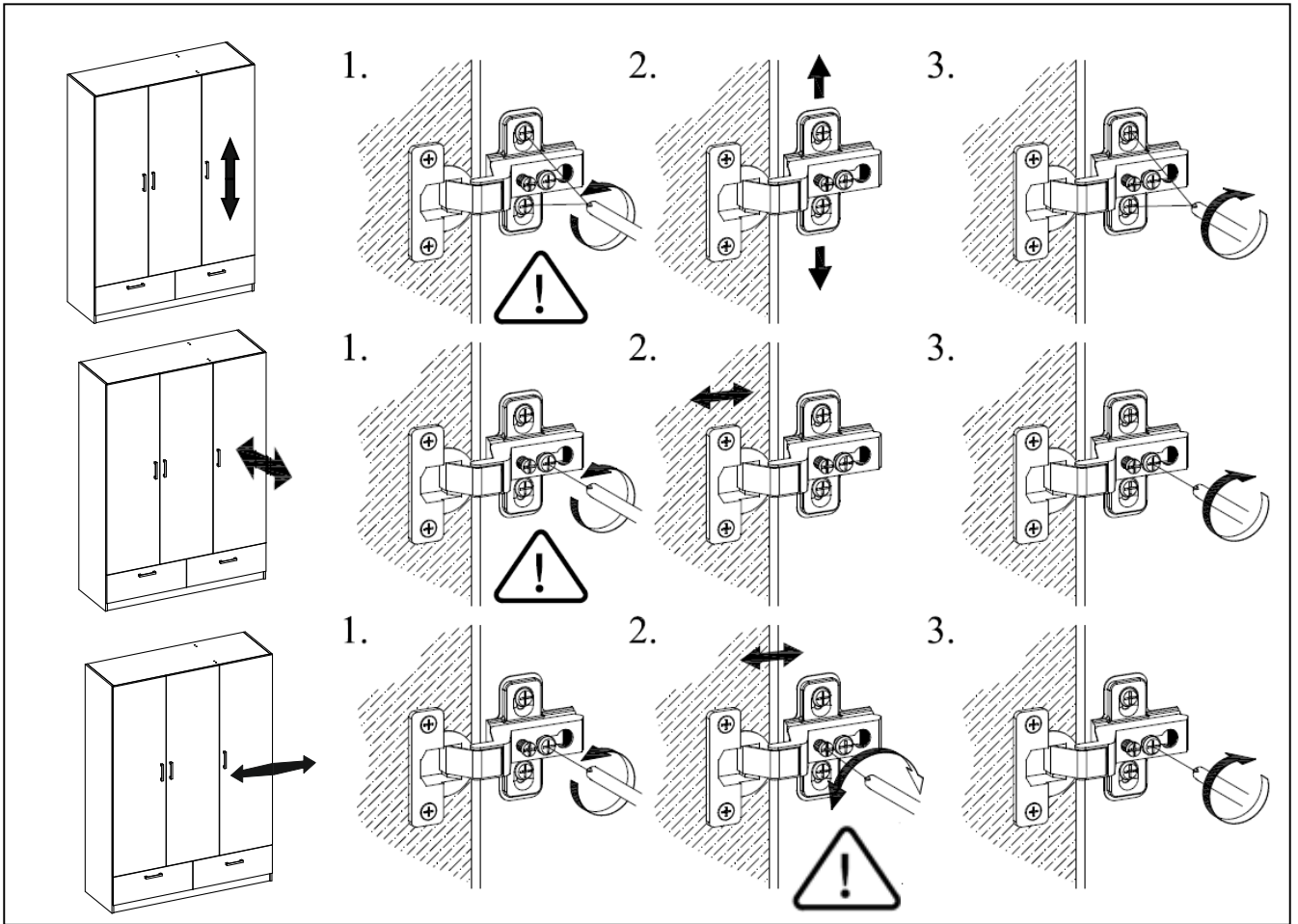
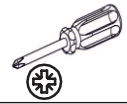

31

Cx4



Ø 3,5x16 mm

